

 **LORIENT**

**ASSA ABLOY**

**AIR TRANSFER**

**GRILLE**

**INSTALLATION**

**MANUAL**

AIR  
TRANSFER  
GRILL



# We've been designing and manufacturing high performance sealing systems for over 40 years.

And we're passionate about the products we make. Our dedicated R&D and testing facilities rigorously put our sealing systems through their paces – enabling us to enhance product form and function. We've built a strong reputation for design innovation; and for producing the highest quality sealing systems embracing acoustic, smoke, fire and thermal containment; as well as accessibility.

Respected throughout the industry for our technical expertise, we play an active role in helping to shape standards and best practice. We believe in providing excellent levels of customer service; and are at our best working in partnership with you.

**MADE IN  
BRITAIN** 



# AIR TRANSFER GRILLES

Our intumescent air transfer grilles combine air movement with fire protection. Designed to be fitted in doors, walls, ducts, floors & ceilings; they provide a cost effective solution in allowing free air movement and yet maintain the integrity of the application in a fire situation.

Our range of combined intumescent fire & smoke air transfer grilles can be used in all applications where cold smoke containment is required. These air transfer grilles are connected, via a control panel, to a standard fire alarm system. In the event of an alarm condition, or power failure, the smoke shutters close, preventing the passage of cold smoke.

## Contents

# INTUMESCENT AIR TRANSFER GRILLES

On average 216 people are killed and 5,545 are injured\* in fires each year in the UK alone. Many of the casualties are attributable to breathing the toxic products of combustion from a remote fire.

## Design Needs and Regulatory Requirements

When fire breaks out in a building the threat is twofold. Firstly, there is the fire itself and the hot smoke generated in the immediate vicinity. Secondly, there is cold smoke which will spread rapidly through the building, threatening people and property some distance from the fire. The Building Regulations take both these threats into account, and supporting documents give criteria for how they can be managed. Details can be found in Approved Document B (England & Wales), Technical Booklet E (N Ireland), and Technical Handbook Section 2 (Scotland).

Sub-dividing buildings into smaller fire resisting compartments is a recognised method to limit the spread of fire. Building a fire resistant wall or floor to construct an enclosed compartment is relatively simple. However, building design becomes much more complex when the compartments need to be linked for everyday use.

## Ventilation through ducting

Designers recognise the need for buildings to be well ventilated for the health and comfort of occupants. Frequent changes of air are required to flush out airborne infections, and warm and cool air needs to be circulated to maintain a comfortable temperature.

Experience has shown that ductwork can, in the event of fire, provide a conduit for fire, as well as the hot smoke and toxic gases it produces.

As HVAC systems frequently penetrate fire compartment boundaries, it is these points that must be treated in an approved manner to preserve the integrity of the fire compartment.

The Lorient solution is to install an intumescent air transfer grille into the duct at the point where it penetrates the fire resistant construction.

This will effectively limit the spread of fire and restrict the passage of hot smoke and toxic gases.

## Intumescent Air Transfer Grilles

Lorient fire containment air transfer grilles are made up of either PVC or metal slats with an intumescent core.

Under normal circumstances they allow air to pass freely but a sudden increase in temperature, resulting from the presence of hot flames or gases, will cause the slats to expand to many times their original thickness fusing together to form a stable fire resistant barrier, which restricts fire and limits the spread of hot smoke and toxic gases.

## Cold smoke containment

Our range of combined intumescent fire & smoke air transfer grilles can be used in all applications where cold smoke containment is required. The air transfer grilles are connected, via a control panel, to a standard fire alarm system. In the event of an alarm condition, or power failure, the smoke shutters shut, preventing the passage of cold smoke.

## Fire and Smoke

There are several Standards which relate to the products and solutions featured in this brochure. They include:

- ▶ BS 476-22:1987: Methods for determination of the fire resistance of non-loadbearing elements of construction;
- ▶ BS 476-31.1:1983: Methods for measuring smoke penetration through doorset and shutter assemblies;
- ▶ BS 9999:2017: Code of practice for fire safety in the design, management and use of buildings;
- ▶ BS EN 1364-5: 2017: Fire resistance tests for non-loadbearing elements. Air transfer grilles;
- ▶ BS EN 1366-12: 2014+A1:2019: Fire resistance tests for service installations. Non-mechanical fire barrier for ventilation ductwork;
- ▶ BS EN 1634-1:2014+A1:2018: Fire resistance and smoke control tests for door, shutter and, openable window assemblies and elements of building hardware. Fire resistance tests for doors, shutters and openable windows;
- ▶ BS EN 1634-3:2004: Fire resistance and smoke control tests for door and shutter assemblies, openable windows and elements of building hardware. Smoke control test for door and shutter assemblies;
- ▶ BS ISO 10294-5:2005: Fire-resistance tests. Fire dampers for air distribution systems. Intumescent fire dampers.

## Comprehensive Range

Lorient offers a comprehensive range of intumescent air transfer grilles that combine air movement with fire protection. Our air transfer grilles are:

- ▶ Durable with a robust construction
- ▶ Maintenance free
- ▶ Easy to install
- ▶ Cost effective – combining air movement & fire protection.



▲ Images: Lorient LVHC44 & LVN20 air transfer grilles

# PRODUCT RANGE

Further information on the products, including sizes, shapes and finishes, can be found on pages 24 - 40. Application details and additional performance information can be found on pages 17 - 23.

AIR TRANSFER GRILLES: FIRE

(PAGES 24–32)



LVN20



LVV40



LVH44



LVN25



LVC40



LVHC44

COVER GRILLES (PAGES 48- 51)



LVH50



LVH54



COVER GRILLES





↑ LVN20S



↑ LVN25S



↑ LVV40S



↑ LVH44S



↑ LVHCTD

CONDUCTOR HINGE (PAGE 36)

TALKBACK (PAGES 41–46)

SEALANT (PAGE 52)

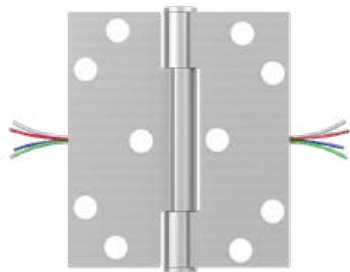

↑ CONDUCTOR HINGE



↑ TALKBACK DAMPER CONTROL SYSTEM



↑ CE INTUMESCENT ACOUSTIC ACRYLIC SEALANT

SEALANT (PAGE 53)

FLANGES



↑ INTUMESCENT SEALANT

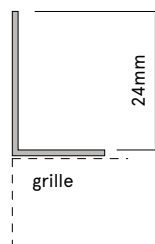

↑ LV2516 STEEL FLANGE

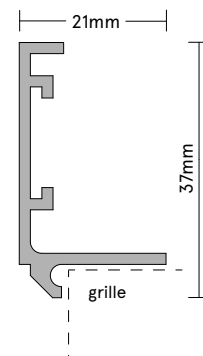

↑ LV2221 ALUMINIUM FLANGE

System		Building Element	Thickness	Protection	Product
Door 1	▲	Timber fire door	44mm/ 54mm	FD30/FD60	LVV40
Door 2	▲	Timber fire door	44mm	FD30	LVN20
Door 3	▲	Timber fire door	Min. 50mm	FD30	LVN25
Door 3	▲	Timber fire door	54mm	FD60	LVN25
Door 4	▲	Mineral composite	45mm	FD120	LVH44
Door 5	▲	Timber fire door	Min. 44mm	FD120	LVH44
Door 6	▲	Steel fire door	Min. 44mm	FD120	LVH44
Door 7	▲ ▲	Timber fire door	44mm	FD30S	LVN20S
Door 8	▲ ▲	Timber fire door	54mm	FD60S	LVN20S
Door 9	▲ ▲	Timber fire door	Min. 50mm	FD30S	LVN25S
Door 10	▲ ▲	Timber fire door	54mm	FD60S	LVN25S
Door 11	▲	Timber frame	*Frame	FR120	LVH44
Door 12	▲	Timber frame	*Frame	FR120	LVH44
Door 13	▲	Timber frame	*Frame	FR120	LVH44
Door 14	▲	Steel frame	*Frame	FR120	LVH44
Door 15	▲	Steel frame	*Frame	FR120	LVH44
Door 16	▲	Steel frame	*Frame	FR120	LVH44
Wall 1	▲	Rigid wall construction	-	FR120	LVH44
Wall 2	▲	Rigid wall construction	-	FR120	LVH44
Wall 3	▲	Rigid wall construction	-	FR120	LVH44
Wall 4	▲	FR Flexible wall	-	FR120	LVH44
Wall 5	▲	FR Flexible wall	-	FR120	LVH44
Wall 6	▲	FR Flexible wall	-	FR120	LVH44
Wall 7	▲	Rigid wall construction	-	FR120	LVH44
Wall 8	▲	Modular system for rigid wall construction	-	FR120	LVH44
Wall 9	▲	Modular system for rigid wall construction	-	FR120	LVH44
Wall 11	▲	Rigid wall construction	-	FR120/EI90	LVH44
Wall 12	▲	Rigid wall construction	-	FR60	LVV40
Wall 13	▲	Rigid wall construction	-	FR60	LVC40
Wall 14	▲	Rigid wall construction	-	E1120	LVV40
Wall 15	▲	FR Flexible Wall	-	EI60	LVV40
Wall 16	▲ ▲	Rigid wall construction	-	EI60S/FR90S	LVV40S
Wall 17	▲ ▲	FR Flexible wall	-	EI60S	LVV40S
Wall 18	▲ ▲	Rigid wall construction	-	FR120	LVH44S
Wall 19	▲ ▲	FR Flexible wall	-	FR120	LVH44S

\*Timber or steel frame as part of associated doorset framing system.

Test Standard	Report No.	Max Size	Certifire	Certifire Max Size
BS 476-20:1987	WF185829/A	600mm x 600mm	CF564	600mm x 600mm
BS 476-22:1987	WFRC C122567	0.36m <sup>2</sup>	CF564	0.2025m <sup>2</sup>
BS 476-22:1987	WFRC C122567	0.36m <sup>2</sup>	CF564	0.2025m <sup>2</sup>
BS 476-22:1987	WFRC C122567	0.36m <sup>2</sup>	CF564	0.2025m <sup>2</sup>
BS 476-22:1987	WFRC C397901	0.2025m <sup>2</sup>	CF564	0.2025m <sup>2</sup>
BS 476-22:1987	WFRC C397901	0.2025m <sup>2</sup>	CF564	0.2025m <sup>2</sup>
BS 476-22:1987	WFRC C397901	0.2025m <sup>2</sup>	CF564	0.2025m <sup>2</sup>
BS 476-22:1987	-	0.16m <sup>2</sup>	CF564	0.16m <sup>2</sup>
BS 476-22:1987	APPLUS-19-19940-1428	350mm x 350mm	CF564	0.16m <sup>2</sup>
BS 476-22:1987	-	400mm x 400mm	CF564	0.16m <sup>2</sup>
BS 476-22:1987	APPLUS-19-19940-1428	350mm x 350mm	CF564	0.16m <sup>2</sup>
BS 476-22:1987	WRFC C121316 (AW4T1)	1200mm x 600mm	-	-
BS 476-22:1987	WRFC C121316 (AW4T2)	1200mm x 600mm	-	-
BS 476-22:1987	WRFC C121316 (AW4T3)	1200mm x 600mm	-	-
BS 476-22:1987	WRFC C121316 (AW4S1)	1200mm x 600mm	-	-
BS 476-22:1987	WRFC C121316 (AW4S2)	1200mm x 600mm	-	-
BS 476-22:1987	WRFC C121316 (AW4S3)	1200mm x 600mm	-	-
BS 476-22:1987	WRFC C121316 (AW1)	600mm x 600mm	CF564	0.2025m <sup>2</sup>
BS 476-22:1987	WRFC C121316 (AW2)	600mm x 600mm	CF564	0.2025m <sup>2</sup>
BS 476-22:1987	WRFC C121316 (AW3)	600mm x 600mm	CF564	0.2025m <sup>2</sup>
BS 476-22:1987	FSP 1970 / FRT 230055	600mm x 600mm	-	-
BS 476-22:1987	FSP 1970 / FRT 230055	600mm x 600mm	-	-
BS 476-22:1987	FSP 1970 / FRT 230055	600mm x 600mm	-	-
BS 476-22:1987	WRFC C121316 (AW7)	600mm x 600mm	-	-
BS 476-22:1987	WRFC C121316 (AW8)	1800mm x 600mm	-	-
BS 476-22:1987	WRFC C121316 (AW9)	1200mm x 600mm	-	-
BS EN 1364-5:2017	19/19894-253	1000mm (w) x 500mm (h)	-	-
BS 476-22:1987	WF185829/A	600mm x 600mm	CF564	600mm x 600mm
BS 476-22:1987	WF185829/A	600mm x 600mm	CF654	600mm x 600mm
BS EN 1364-5:2017	19/19894-253	600mm x 600mm	-	-
BS EN 1364-5:2017	LBO-1333/19E	600mm x 600mm	-	-
BS 476-20:1987 BS EN 1364-5:2017	18/17274-1071	600mm (w) x 400mm (h) (640mm x 440mm overall)	CF564	0.2025m <sup>2</sup>
BS EN 1364-5:2017	LBO-1333/19E	600mm (w) x 400mm (h) (640mm x 440mm overall)	-	-
BS 476-22:1987	WRFC C121316	600mm x 600mm (640mm x 640mm overall)	-	-
BS 476-22:1987	WRFC C121316	600mm x 600mm (640mm x 640mm overall)	-	-

DUCTS

System	 	Building Element	Thickness	Protection	Product
Duct 1	▲	Circular plastic pipe	-	FR60	LVC40
Duct 2	▲	Circular steel duct	-	FR60	LVC40
Duct 3	▲	Rectangular steel duct	-	FR120	LVH44
Duct 4	▲	Insulated duct section	-	FR120	LVH44
Duct 5	▲	Rigid wall construction with angle fixings to wall (Duct to Duct)	-	FR120	LVHC44
Duct 6	▲	Rigid wall construction with angle clamps (Duct to Duct)	-	FR120	LVHC44
Duct 7	▲	FR Flexible wall with angle fixings to wall	-	FR120	LVHC44
Duct 8	▲	FR Flexible wall with angle clamps	-	FR120	LVHC44
Duct 9	▲	Rigid wall construction with angle fixings (Duct to Grille)	-	FR120	LVHC44
Duct 10	▲	Rigid wall construction (Duct to Duct)	-	FR120	LVH44
Duct 11	▲	FR Flexible wall (Duct to Duct)	-	FR120	LVH44
Duct 12	▲	FR Flexible wall (Duct to Grille)	-	FR120	LVH44
Duct 13	▲	Rigid wall construction with metal casing (Duct to Grille)	-	FR120	LVH44
Duct 14	▲	Rectangular steel duct	-	E240/EI30	LVH54
Duct 15	▲ ▲	Rectangular steel duct	-	FR120*/ FR240**	LVHCTD + LVH44*/ LVH54**
<b>FLOORS</b>					
Floor 1	▲	Masonry floor with angle fixings	-	FR120	LVHC44
Floor 2	▲	Masonry floor with angle clamps	-	FR120	LVHC44
Floor 3	▲	Masonry floor with angle fixings	-	FR120	LVH44
Floor 4	▲	Masonry floor with Z section fixings	-	FR120	LVH44
Floor 5	▲	Masonry floor with Z section fixings using pre-cast slab to suit	-	FR120	LVH44
Floor 6	▲	Fixing on top of masonry floor with angle fixings	-	FR120	LVH44
Floor 7	▲	Modular system for masonry floor	-	FR120	LVH44
Floor 8	▲	Fixing on top of masonry floors with angle fixings (Modular Systems)	-	FR120	LVH44
Floor 9	▲	Masonry floor (Duct to Duct)	-	FR120	LVH44

Test Standard	Report No.	Max Size	Certifire	Certifire Max Size
BS 476-20:1987	WF185829/A	150mm diameter	-	-
BS 476-22:1987	WF185829/A	*600mm diameter **450mm diameter	-	-
BS 476-22:1987	WRFC C121316	600mm x 600mm	-	-
BS 476-22:1987	WRFC C121316	600mm x 600mm	-	-
BS 476-22:1987	WRFC C121316 (OW1) WRFC 397901	600mm diameter	-	-
BS 476-22:1987	WRFC C121316 (OW2) WRFC 397901	600mm diameter	-	-
BS 476-22:1987	WRFC C121316 (OW3) WRFC 397901	600mm diameter	-	-
BS 476-22:1987	WRFC C121316 (OW4) WRFC 397901	600mm diameter	-	-
BS 476-22:1987	WRFC C121316 (OW5) WRFC 397901	600mm diameter	-	-
BS 476-22:1987	WRFC C121316 (W-SERIES)	600mm x 600mm	-	-
BS 476-22:1987	WRFC C121316 (W-SERIES)	600mm x 600mm	-	-
BS 476-22:1987	WRFC C121316 (W-SERIES)	600mm x 600mm	-	-
BS 476-22:1987	WRFC C121316 (W-SERIES)	600mm x 600mm	-	-
ISO 10294-5	BRE 227730	600mm x 600mm	-	-
BS 476-22:1987* ISO 10294-5**	WRFC C121316* BRE 227730**	600mm x 600mm	-	-
BS 476-22:1987	WRFC C121316 (OF1)	600mm diameter	-	-
BS 476-22:1987	WRFC C121316 (OF2)	600mm diameter	-	-
BS 476-22:1987	WRFC C121316 (AF1)	600mm x 600mm	-	-
BS 476-22:1987	WRFC C121316 (AF2)	600mm x 600mm	-	-
BS 476-22:1987	WRFC C121316 (AF3)	600mm x 600mm	-	-
BS 476-22:1987	WRFC C121316 (AF5)	600mm x 600mm	-	-
BS 476-22:1987	WRFC C121316 (AF6)	1200mm x 600mm	-	-
BS 476-22:1987	WRFC C121316 (AF7)	2400mm x 600mm	-	-
BS 476-22:1987	WRFC C121316 (F1)	1200mm x 600mm	-	-

DUCTS

FLOORS

**NOTE:** Mechanical Services Engineers, Specifiers and Certifiers should always request access to manufacturers' primary fire test approvals and satisfy themselves that these relate to the products they are specifying or certifying.

Lorient **DOES NOT** endorse the use of test reports which reference Lorient intumescent air transfer grilles being used to support the certification of other manufacturers' intumescent air transfer grille products.

# DOOR MOUNTED SYSTEMS

Fitted into doors, our intumescent air transfer grilles and fire dampers combine air movement with fire protection. They provide a cost effective solution in allowing free air movement and yet maintain the integrity of the door in a fire situation.

System		Fire Rating	Door Thickness	Application	Product	Detail	Certifire	Page No.
Door 1	▲	FD30/FD60	44mm/54mm	Timber fire door	<b>LVV40</b>	Cover grilles (optional)	CF564	<b>13</b>
Door 2	▲	FD30	44mm	Timber fire door	<b>LVN20</b>	Non-vision	CF564	<b>14</b>
Door 3	▲	FD30	Min. 50mm	Timber fire door	<b>LVN25</b>	Non-vision	CF564	<b>15</b>
Door 3	▲	FD60	54mm	Timber fire door	<b>LVN25</b>	Non-vision	CF564	<b>15</b>
Door 4	▲	FD30/FD60	44mm/54mm	Timber fire door	<b>LVH44</b>	With intumescent liner	-	<b>16</b>
Door 5	▲	FD120	Min. 44mm	Mineral composite fire door	<b>LVH44</b>	With intumescent liner	CF564	<b>17</b>
Door 6	▲	FD120	Min. 44mm	Steel fire door	<b>LVH44</b>	With intumescent liner	CF564	<b>18</b>
Door 7	▲ ▲	FD30S	44mm	Timber fire door	<b>LVN20S</b>	With intumescent liner	CF564	<b>19</b>
Door 8	▲ ▲	FD60S	54mm	Timber fire door	<b>LVN20S</b>	With intumescent liner	CF564	<b>20</b>
Door 9	▲ ▲	FD60S	Min. 50mm	Timber fire door	<b>LVN25S</b>	With intumescent liner	CF564	<b>21</b>
Door 10	▲ ▲	FD60S	54mm	Timber fire door	<b>LVN25S</b>	With intumescent liner	CF564	<b>22</b>
Door 11	▲	FR120	*Frame	Timber frame	<b>LVH44</b>	With intumescent liner	-	<b>23</b>
Door 12	▲	FR120	*Frame	Timber frame	<b>LVH44</b>	With intumescent liner	-	<b>24</b>
Door 13	▲	FR120	*Frame	Timber frame	<b>LVH44</b>	With intumescent liner	-	<b>25</b>
Door 14	▲	FR120	*Frame	Steel frame	<b>LVH44</b>	With intumescent liner	-	<b>26</b>
Door 15	▲	FR120	*Frame	Steel frame	<b>LVH44</b>	With intumescent liner	-	<b>27</b>
Door 16	▲	FR120	*Frame	Steel frame	<b>LVH44</b>	With intumescent liner	-	<b>28</b>

\*Timber or steel frame as part of associated doorset framing system.

# FIRE DOOR 1

## LVV40 AIR TRANSFER GRILLE WITH COVER GRILLES INTO TIMBER FIRE DOOR

### DESCRIPTION

- |   |  |
|---|--|
| 1 | FD30: 44mm thick timber fire door<br>FD60: 54mm thick timber fire door                     |
| 2 | Pressed steel cover grille to door fasteners -<br>25mm wood screws                         |
| 3 | Pressed steel cover grille   |
| 4 | LVV40 intumescent air transfer grille  |
| 5 | Intumescent air transfer grille to door fasteners -<br>40mm wood screws offset to one face |
| 6 | Use sealant to bed air transfer grille into door   |

In order to comply with CF564, the upper edge of the grille shall be no higher than 3000mm from floor level. The lower edge of the grille shall be no closer than 400mm to floor level. Consult door manufacturers before cutting out in relation to permissible aperture sizes and locations

If the door leaf core does not comprise a solid timber lamel core (i.e. a core of chipboard, flaxboard etc.), the aperture provided in the leaf should be lined to full width using hardwood, with a minimum density of 650kg/m<sup>3</sup> and a thickness of at least 6mm. This hardwood liner may be omitted should the leaf have been tested.

### CONTENTS

- LVV40 air transfer grille
- Cover grille (optional)

### TOOLS REQUIRED

- Power drill
- Screw driver
- 40mm wood screws
- Lorient intumescent sealant

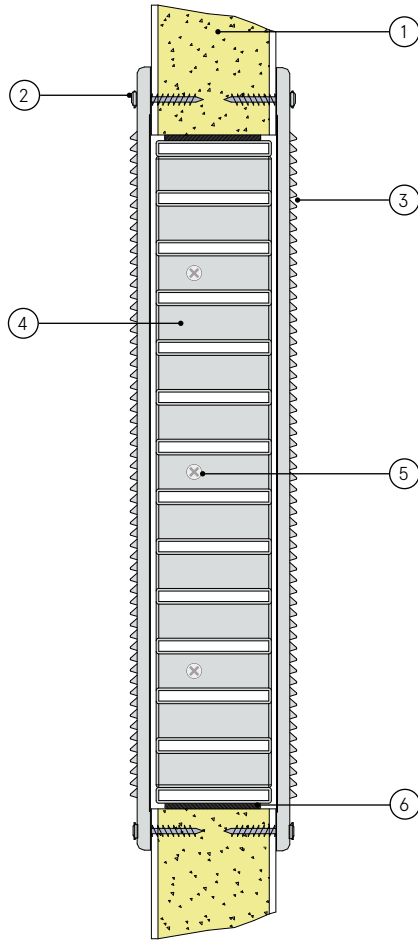

**Note:** Screw holes based on 600mm square grille. Location and number may vary depending on the size of the grille. Max centres 200mm.

### LVV40 into a fire door

#### FD30/60

#### Fire Resistance in accordance with

BS 476-22:1987

#### Approval Ref

WF185829/A

Certifire CF564

#### Max single cell size

600mm x 600mm

LVV40 air transfer grilles are supplied 2mm less than the nominal size e.g. a 300mm x 300mm is actually 298mm x 298mm.

### INSTALLATION INSTRUCTIONS

- ▶ Ensure that cutting an aperture in the door will not detract from the fire integrity of the door. Contact the manufacturer to establish the maximum size and optimum position.
- ▶ Using a 4mm drillbit, drill fixing holes. The number of holes will be dependent on the size of the LVV40. They should be a maximum of 50mm from each corner, no more than 200mm centres.
- ▶ Cut the aperture to the required size with a maximum gap all around of 3mm.
- ▶ Apply Lorient intumescent sealant to the inside faces of the aperture.
- ▶ Fit the LVV40 into the aperture and ensure that it is positioned equidistant from each face and parallel from both faces of the door.
- ▶ Fit retaining wood screws through the fixing holes in LVV40 outer uprights into door.
- ▶ Clean off surplus sealant and ensure outer edge of LVV40 is fully sealed.
- ▶ Position pressed steel cover grille centrally over one face of the LVV40 and fix using 25mm wood screws.
- ▶ Repeat to other face if two cover grilles are to be fitted.
- ▶ **Note: Fixings supplied by others.**

# FIRE DOOR 2

## LVN20 NON-VISION AIR TRANSFER GRILLE INTO TIMBER FIRE DOOR

### DESCRIPTION

- |   |  |
|---|--|
| 1 | 44mm thick timber fire door  |
| 2 | Aluminium mounting flange  |
| 3 | Intumescent air transfer grille to door fasteners - 25mm wood screws |
| 4 | LVN20 intumescent air transfer grille                                |

In order to comply with CF564, the upper edge of the grille shall be no higher than 800mm from floor level. Consult door manufacturers before cutting out in relation to permissible aperture sizes and locations

If the door leaf core does not comprise a solid timber lamel core (i.e. a core of chipboard, flaxboard etc.), the aperture provided in the leaf should be lined to full width using hardwood, with a minimum density of 650kg/m<sup>3</sup> and a thickness of at least 6mm. This hardwood liner may be omitted should the leaf have been tested.

### CONTENTS

- LVN20 air transfer grille
- Aluminium mounting flange (optional)

### TOOLS REQUIRED

- Power drill
- Screw driver
- 25mm wood screws
- Lorient intumescent sealant

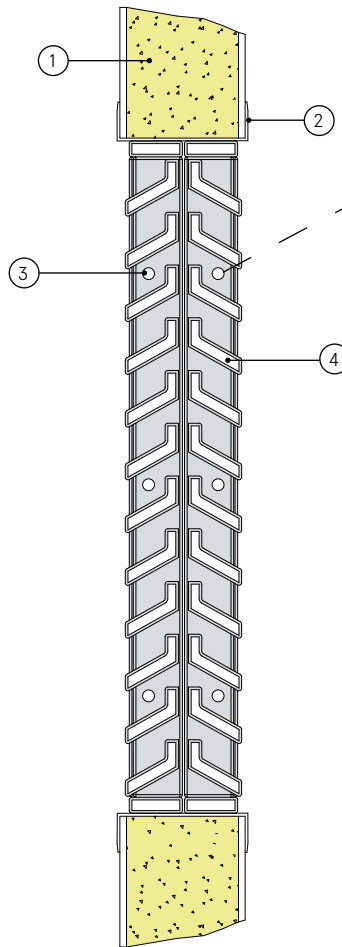

**Note:** Screw holes based on 450mm square grille. Location and number may vary depending on the size of the grille. Max centres 200mm.

### LVN20 into a timber fire door

## FD30

### Fire Resistance in accordance with

BS 476-22:1987

### Approval Ref

WFRC C122567\*

Certifire CF564\*\*

### Max area

0.36m<sup>2</sup>\*

0.2025m<sup>2</sup>\*\*

LVN20 air transfer grilles are supplied 2mm less than the nominal size e.g. a 300mm x 300mm is actually 298mm x 298mm, but the PVC mounting flange needs an extra 4mm overall, giving total dimensions 2mm greater than the nominal size. e.g. 302mm x 302mm.

### INSTALLATION INSTRUCTIONS

- ▶ Ensure that cutting an aperture in the door will not detract from the fire integrity of the door. Contact the manufacturer to establish the maximum size and optimum position.
- ▶ Cut the aperture to the required size with a maximum gap all around of 3mm. e.g. Maximum dimensions 306mm x 306mm.
- ▶ The door leaf does not compromise a solid timber lamel core (i.e. a core of chipboard, hardboard etc.), the aperture provided should be lined the full width using hardwood (minimum density of 650kg/m<sup>3</sup> and thickness of 6mm).
- ▶ Apply a bead of Lorient intumescent sealant around the aperture approx. 1cm from both sides of the door surface. This will provide a bed for the LVN20.
- ▶ Using a 4mm drillbit, drill fixing holes. The number of holes will be dependent on the size of the LVN20. They should be a maximum of 50mm from each corner, no more than 200mm centres.
- ▶ Fit one half of the LVN20 into the aperture and ensure that it is positioned with the flange snug to the face.
- ▶ Fit retaining wood screws through pre-drilled holes in the LVN20 vertical outer uprights into door.
- ▶ Clean off surplus sealant and ensure periphery of half of the LVN20 is fully sealed.
- ▶ Repeat the process with the remaining half of the LVN20.
- ▶ **Note: Fixings supplied by others.**



# FIRE DOOR 3

## LVN25 NON-VISION AIR TRANSFER GRILLE INTO TIMBER FIRE DOOR

### DESCRIPTION

- 1 FD30: Minimum 50mm thick timber fire door  
FD60: 54mm thick timber fire door
- 2 Aluminium mounting flange
- 3 Intumescent air transfer grille to door fasteners - 25mm wood screws
- 4 LVN25 intumescent air transfer grille

In order to comply with CF564, the upper edge of the grille shall be no higher than 800mm from floor level. Consult door manufacturers before cutting out in relation to permissible aperture sizes and locations

If the door leaf core does not comprise a solid timber lamel core (i.e. a core of chipboard, flaxboard etc.), the aperture provided in the leaf should be lined to full width using hardwood, with a minimum density of 650kg/m<sup>3</sup> and a thickness of at least 6mm. This hardwood liner may be omitted should the leaf have been tested.

### CONTENTS

- LVN25 air transfer grille
- Aluminium mounting flange (optional)

### TOOLS REQUIRED

- Power drill
- Screw driver
- 25mm wood screws
- Lorient intumescent sealant

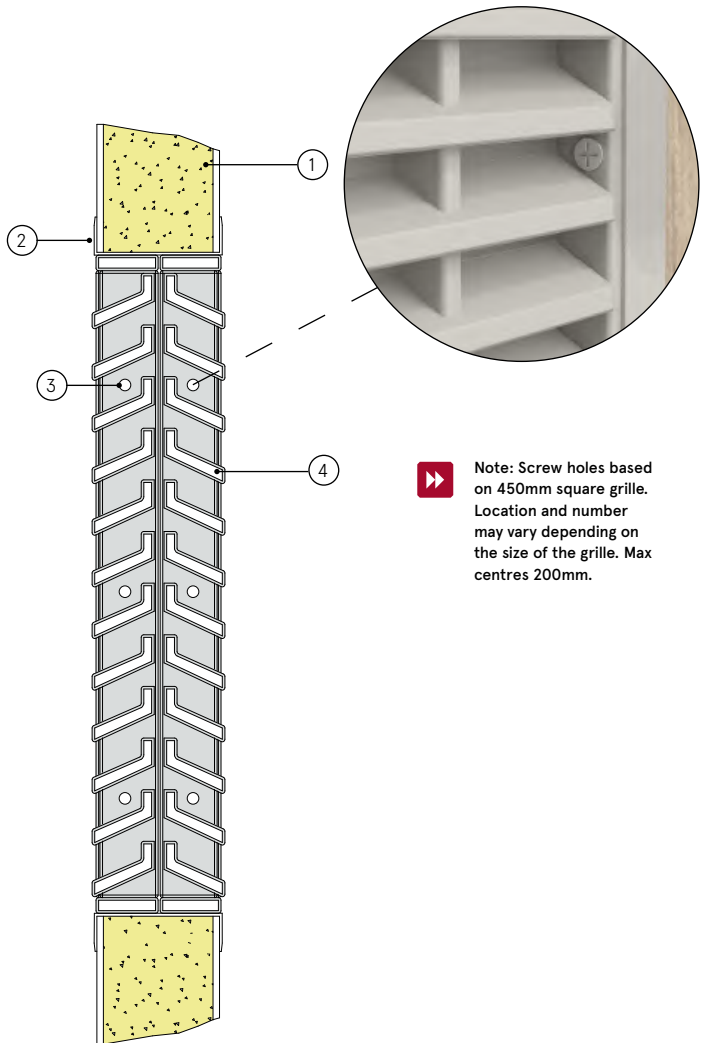

**Note:** Screw holes based on 450mm square grille. Location and number may vary depending on the size of the grille. Max centres 200mm.

### LVN25 into a timber fire door

## FD30/FD60

### Fire Resistance in accordance with

BS 476-22:1987

### Approval Ref

WFRC C122567\*

Certifire CF564\*\*

### Max single cell size

0.36m<sup>2</sup>\*

0.2025m<sup>2</sup>\*\*

LVN25 air transfer grilles are supplied 2mm less than the nominal size e.g. a 300mm x 300mm is actually 298mm x 298mm, but the PVC mounting flange needs an extra 4mm overall, giving total dimensions 2mm greater than the nominal size. e.g. 302mm x 302mm.

### INSTALLATION INSTRUCTIONS

- ▶ Ensure that cutting an aperture in the door will not detract from the fire integrity of the door. Contact the manufacturer to establish the maximum size and optimum position.
- ▶ Cut the aperture to the required size with a maximum gap all around of 3mm. e.g. Maximum dimensions 306mm x 306mm.
- ▶ The door leaf does not compromise a solid timber lamel core (i.e. a core of chipboard, hardboard etc.), the aperture provided should be lined to the full width using hardwood (minimum density of 650kg/m<sup>3</sup> and thickness of 6mm).
- ▶ Apply a bead of Lorient intumescent sealant around the aperture approx. 1cm from both sides of the door surface. This will provide a bed for the LVN25.
- ▶ Pre-drill vertical outer frames of LVN25 to accept fixing screws.
- ▶ Fit a half of the LVN25 into the aperture and ensure that it is positioned with the flange snug to the face.
- ▶ Fit retaining wood screws through pre-drilled holes in LVN25 vertical outer uprights into door.
- ▶ Clean off surplus sealant and ensure periphery of half of the LVN25 is fully sealed.
- ▶ Repeat the process with the remaining half of the LVN25.
- ▶ **Note: Fixings supplied by others.**

# FIRE DOOR 4

## LVH44 AIR TRANSFER GRILLE WITH COVER GRILLES INTO TIMBER FIRE DOOR

### DESCRIPTION

- |   |  |
|---|--|
| 1 | FD30: 44mm thick timber fire door.<br>FD60: 54mm thick timber door   |
| 2 | Grille to door fasteners - 25mm wood screws                          |
| 3 | Pressed steel cover grille   |
| 4 | LVH44 intumescent air transfer grille                                |
| 5 | Intumescent air transfer grille to door fasteners - 25mm wood screws |
| 6 | Intumescent liner.   |

### CONTENTS

- LVH44 air transfer grille
- Intumescent liner (LX4402) or (LX5402)
- Cover grille (optional)

### TOOLS REQUIRED

- 25mm wood screws
- Power drill
- Screw driver

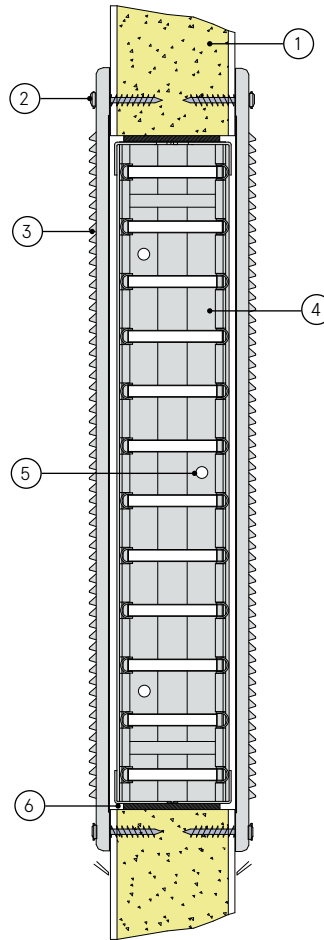

**Note:** Screw holes based on 600mm square grille. Location and number may vary depending on the size of the grille. Max centres 200mm.

### LVH44 into a timber fire door

#### FD30/60

#### Fire Resistance in accordance with

BS 476-22:1987

#### Approval Ref

WFRC C397901

#### Max single cell size

600mm x 600mm

LVH44 air transfer grilles are supplied 2mm less than the nominal size e.g. a 300mm x 300mm is actually 298mm x 298mm.

### INSTALLATION INSTRUCTIONS

- ▶ Ensure that cutting an aperture in the door will not detract from the fire integrity of the door. Contact the manufacturer to establish the maximum size and optimum position.
- ▶ Cut the aperture to the required size with a maximum gap all around of 3mm.
- ▶ Pre-drill vertical outer frames of LVH44 to accept fixing screws.
- ▶ Apply Lorient intumescent liner to the inside faces of the aperture.
- ▶ Fit the LVH44 into the aperture and ensure that it is positioned equidistant from each face and parallel from both faces of the door.
- ▶ Fit retaining wood screws through pre-drilled holes in LVH44 vertical outer uprights into door.
- ▶ Position pressed steel cover grille centrally over one face of the LVH44 and fix using screws.
- ▶ Repeat to other face if two cover grilles are to be fitted.
- ▶ **Note: Fixings supplied by others.**

# FIRE DOOR 5

## LVH44 AIR TRANSFER GRILLE WITH COVER GRILLES INTO MINERAL COMPOSITE FIRE DOOR

### DESCRIPTION

- 1 Minimum 44mm thick mineral composite fire door
- 2 Grille to door fasteners - 25mm wood screws
- 3 Pressed steel cover grille
- 4 LVH44 intumescent air transfer grille
- 5 Intumescent air transfer grille to door fasteners - 25mm wood screws
- 6 Intumescent liner

In order to comply with CF564, the upper edge of the grille shall be no higher than 3000mm from the floor level. The lower edge of the grille shall be no closer than 200mm to floor level. Consult door manufacturers before cutting out in relation to permissible aperture sizes and locations.

### CONTENTS

- LVH44 air transfer grille
- Intumescent liner (LX4402)
- Cover grille (optional)

### TOOLS REQUIRED

- 25mm wood screws
- Power drill
- Screw driver

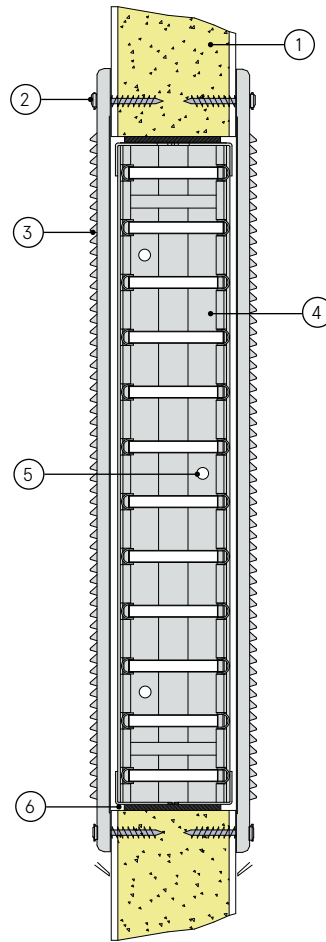

**Note:** Screw holes based on 600mm square grille. Location and number may vary depending on the size of the grille. Max centres 200mm.

### LVH44 into a mineral composite fire door

#### FD120

#### Fire Resistance in accordance with

BS 476-22:1987

#### Approval Ref

WFRC C397901  
CF564\*

#### Max single cell size

600mm x 600mm

\*Any rectangular shape up to 0.2025m<sup>2</sup>

LVH44 air transfer grilles are supplied 2mm less than the nominal size e.g. a 300mm x 300mm is actually 298mm x 298mm.

### INSTALLATION INSTRUCTIONS

- ▶ Ensure that cutting an aperture in the door will not detract from the fire integrity of the door. Contact the manufacturer to establish the maximum size and optimum position.
- ▶ Cut the aperture to the required size with a maximum gap all around of 3mm.
- ▶ Pre-drill vertical outer frames of LVH44 to accept fixing screws.
- ▶ Apply Lorient intumescent liner to the inside faces of the aperture.
- ▶ Fit the LVH44 into the aperture and ensure that it is positioned equidistant from each face and parallel from both faces of the door.
- ▶ Fit retaining wood screws through pre-drilled holes in LVH44 vertical outer uprights into door.
- ▶ Position pressed steel cover grille centrally over one face of the LVH44 and fix using screws.
- ▶ Repeat to other face if two cover grilles are to be fitted.
- ▶ **Note: Fixings supplied by others.**

# FIRE DOOR 6

## LVH44 AIR TRANSFER GRILLE WITH COVER GRILLES INTO STEEL FIRE DOOR

### DESCRIPTION

- |   |  |
|---|--|
| 1 | Minimum 44mm thick steel fire door   |
| 2 | Grille to door fasteners - self tapping screws   |
| 3 | Pressed steel cover grille   |
| 4 | LVH44 intumescent air transfer grille  |
| 5 | Intumescent air transfer grille to door fasteners - self tapping screws (3.2mm x 16mm) |
| 6 | Intumescent liner  |

In order to comply with CF564, the upper edge of the grille shall be no higher than 3000mm from the floor level. The lower edge of the grille shall be no closer than 200mm to floor level. Consult door manufacturers before cutting out in relation to permissible aperture sizes and locations.

### CONTENTS

- LVH44 air transfer grille
- Intumescent liner (LX4402)
- Cover grille (optional)

### TOOLS REQUIRED

- Self tapping screws (3.2 x 16mm)
- Power drill
- Screw driver

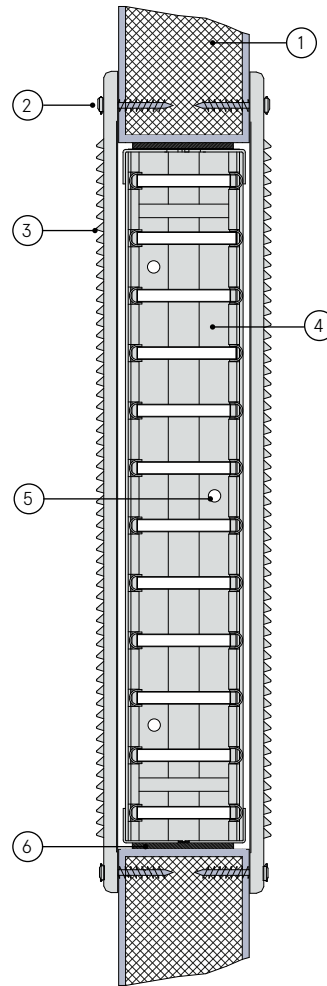

Note: Screw holes based on 600mm square grille. Location and number may vary depending on the size of the grille. Max centres 200mm.

### LVH44 into a steel fire door

### FD120

### Fire Resistance in accordance with

BS 476-22:1987

### Approval Ref

WFRC C397901  
CF564\*

### Max single cell size

600mm x 600mm

\*Any rectangular shape up to 0.2025m<sup>2</sup>

LVH44 air transfer grilles are supplied 2mm less than the nominal size e.g. a 300mm x 300mm is actually 298mm x 298mm.

### INSTALLATION INSTRUCTIONS

- ▶ Ensure that cutting an aperture in the door will not detract from the fire integrity of the door. Contact the manufacturer to establish the maximum size and optimum position.
- ▶ Form the aperture to the required size with a maximum gap all around of 3mm.
- ▶ Pre-drill vertical outer frames of LVH44 to accept fixing screws.
- ▶ Apply Lorient intumescent liner to the inside faces of the aperture.
- ▶ Fit the LVH44 into the aperture and ensure that it is positioned equidistant from each face and parallel from both faces of the door.
- ▶ Fit retaining self tapping screws through pre-drilled holes in LVH44 vertical outer uprights into door.
- ▶ Position pressed steel cover grille centrally over one face of the LVH44 and fix using screws.
- ▶ Repeat to other face if two cover grilles are to be fitted.
- ▶ Note: Fixings supplied by others.

# FIRE DOOR 7

## LVN20S NON-VISION FIRE + SMOKE AIR TRANSFER GRILLE INTO FD30S TIMBER FIRE DOOR

### DESCRIPTION

- |   |  |
|---|--|
| 1 | 44mm thick timber fire door  |
| 2 | Mounting flange  |
| 3 | Horizontal intumescent louvred slats   |
| 4 | Air transfer grille to door fixing position                                  |
| 5 | Hit + miss smoke control plates. Central plate moves, two fixed outer plates |
| 6 | Servo driven actuator  |
| 7 | Intumescent liner (LX4402) between the air transfer grille and the door leaf |
| 9 | Drop seal (optional)   |

In order to comply with CF564, the upper edge of the grille shall be no higher than 800mm from floor level. Door manufacturers must be consulted in relation to permissible aperture sizes and locations.

If the door core is not a solid timber lamel core (e.g. chipboard, flaxboard etc.), the aperture must be lined to full width using hardwood, with a minimum density of 650kg/m<sup>3</sup> and a thickness of at least 6mm. This may be omitted if the leaf has supporting test evidence.

### CONTENTS

- LVN20S fire + smoke resistant air transfer grille
- Mounting flange
- Lorient intumescent liner (LX4402)

### TOOLS REQUIRED

- 40mm wood screws
- Power drill
- Screw driver

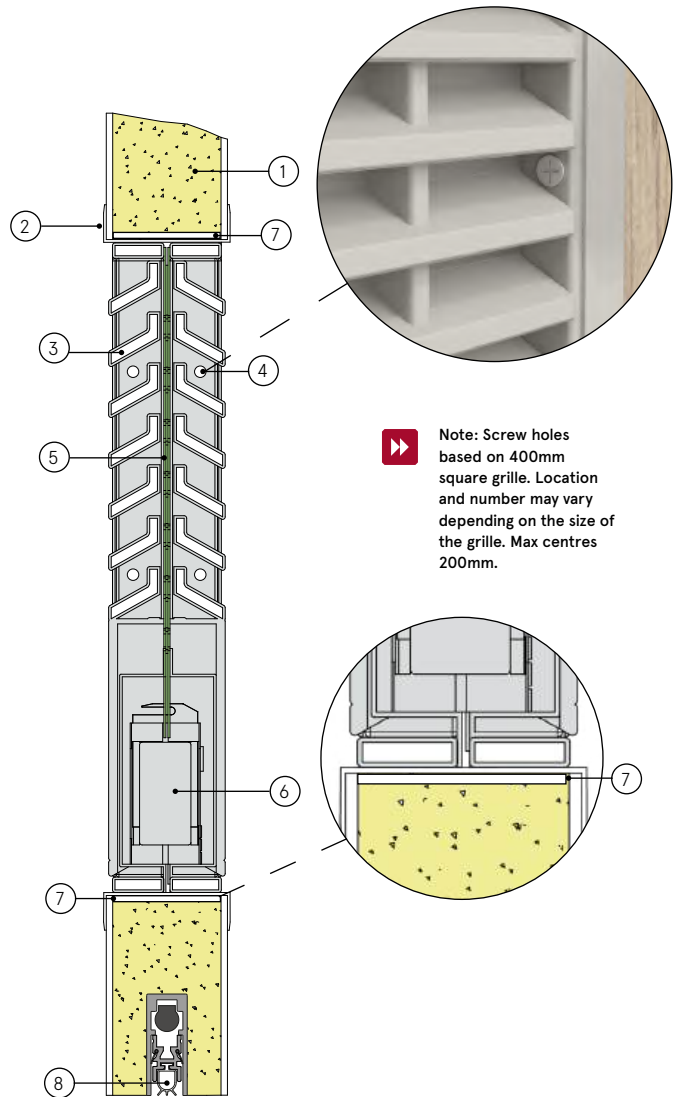

**Note:** Screw holes based on 400mm square grille. Location and number may vary depending on the size of the grille. Max centres 200mm.

### LVN20S in a 44mm FD30S timber fire door

## FD30S

### Fire Resistance in accordance with

BS 476-22:1987

### Approval Ref

CF564

### Max single cell size

400x400mm / 0.16m<sup>2</sup> at up to 800mm above FFL\*\*

Requires an aperture 9mm over size. E.g. a 300mm x 300mm needs an aperture 309mm x 309mm to accommodate the flange.

### INSTALLATION INSTRUCTIONS

- ▶ Ensure that cutting an aperture in the door will not detract from the fire integrity of the door. Contact the manufacturer to establish the maximum size and optimum position.
- ▶ The initial installation of this type of air transfer grille is best carried out with the door dismantled. If rebated threshold seal is to be fitted this should be done temporarily before fitting the LVN20S assembly and then removed.
- ▶ Cut the aperture to the required size with a maximum gap all around the outside of the flange of 9mm.
- ▶ Check that the two halves of the air transfer grille fit into the aperture without twisting jamming or in any way distorting. Remove LVN20S sub assemblies from aperture.
- ▶ Drill vertical outer frames of each air transfer grille and flange sub assembly to accept fixing screws if not pre-drilled when supplied.
- ▶ Drill and rebate door to provide wiring route to conductor hinges or loop connection (refer to conductor hinge datasheet).
- ▶ Fit intumescent liner (LX4402) to the inside faces of the aperture.
- ▶ Fit the LVN20S sub assembly that incorporates the actuator into the aperture, ensuring that the actuator is at the bottom of the aperture. Route the wiring in to the required connection (hinge or loop) ensuring that it lies tidily and does not cause any distortion of the damper or is likely to become trapped.
- ▶ Fit retaining wood screws through pre-drilled holes in LVN20S vertical outer uprights into door.
- ▶ **Refer to wiring instructions.**
- ▶ Carry out a function check of the air transfer grille by activation from the control unit whilst the actuator is visible and wiring accessible, before fitting the remaining half of the LVN20S.
- ▶ After satisfactorily completing function check, fit the remaining half LVN20S assembly ensuring that the smoke control sliding plates do not become squeezed between the two air transfer grille halves or wiring becomes trapped.
- ▶ Repeat the function check on complete installation.

# FIRE DOOR 8

## LVN20S NON-VISION FIRE + SMOKE AIR TRANSFER GRILLE INTO TIMBER FIRE DOOR

### DESCRIPTION

- |   |  |
|---|--|
| 1 | 54mm thick timber fire door  |
| 2 | Mounting flange  |
| 3 | Horizontal intumescent louvred slats                                     |
| 4 | Air transfer grille to door fasteners - 40mm wood screws                 |
| 5 | Hit + miss smoke control plates. Central plate moves, outer plates fixed |
| 6 | Servo driven actuator  |
| 7 | Intumescent liner (LX5402) between the air transfer grille and the door  |
| 8 | Drop seal (optional)   |

In order to comply with CF564, the upper edge of the grille shall be no higher than 800mm from floor level. Consult door manufacturer before cutting out in relation to permissible aperture sizes and locations

If the door leaf core does not comprise a solid timber lamel core (i.e. a core of chipboard, flaxboard etc.), the aperture provided in the leaf should be lined to full width using hardwood, with a minimum density of 650kg/m<sup>3</sup> and a thickness of at least 6mm. This hardwood liner may be omitted should the leaf have been tested.

### CONTENTS

- LVN20S fire + smoke resistant air transfer grille

- Lorient intumescent liner (LX5402)
- Mounting flange
- Wiring instructions

### TOOLS REQUIRED

- 40mm wood screws
- Power drill
- Screw driver

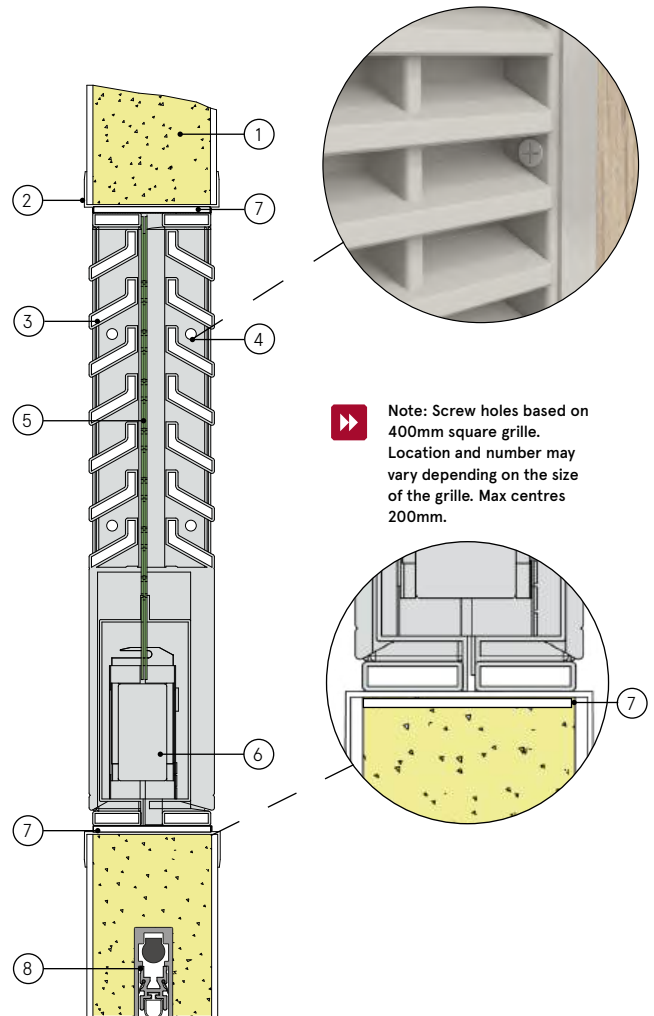

**Note:** Screw holes based on 400mm square grille. Location and number may vary depending on the size of the grille. Max centres 200mm.

### LVN20S into a timber fire door FD60S

#### Fire Resistance in accordance with

BS 476-22:1987

#### Approval Ref

Applus-19-19940-1428\*  
CF564\*\*

#### Max single cell size

350x350mm at up to 1350mm above FFL\*  
400x400mm / 0.16m<sup>2</sup> at up to 800mm above FFL\*\*

Requires an aperture 9mm over size. e.g. a 300mm x 300mm needs an aperture 309mm x 309mm to accommodate the flange.

### INSTALLATION INSTRUCTIONS

- ▶ Ensure that cutting an aperture in the door will not detract from the fire integrity of the door. Contact the manufacturer to establish the maximum size and optimum position.
- ▶ The initial installation of this type of air transfer grille is best carried out with the door dismantled. If a rebated threshold seal is to be fitted this should be done temporarily before fitting the LVN20S assembly and then removed.
- ▶ Cut the aperture to the required size with a maximum gap all around the outside of the flange of 9mm.
- ▶ Check that the two halves of the air transfer grille fit into the aperture without twisting jamming or in any way distorting. Remove LVN20S sub assemblies from aperture.
- ▶ Drill vertical outer frames of each air transfer grille and flange sub assembly to accept fixing screws if not pre-drilled when supplied.
- ▶ Drill and rebate door to provide wiring route to conductor hinges or loop connection (refer to conductor hinge datasheet).
- ▶ Fit intumescent liner (LX5402) to the inside faces of the aperture.
- ▶ Fit the LVN20S sub assembly that incorporates the actuator into the aperture, ensuring that the actuator is at the bottom of the aperture. Route the wiring in to the required connection (hinge or loop) ensuring that it lies tidily and does not cause any distortion of the damper or is likely to become trapped.
- ▶ Fit retaining wood screws through pre-drilled holes in LVN20S vertical outer uprights into door.
- ▶ Refer to wiring instructions.
- ▶ Carry out a function check of the air transfer grille by activation from the control unit whilst actuator is visible and wiring accessible, before fitting the remaining half of the LVN20S.
- ▶ After satisfactorily completing function check, fit the remaining half LVN20S assembly ensuring that the smoke control sliding plates do not become squeezed between the two air transfer grille halves or wiring becomes trapped.
- ▶ Repeat the function check on complete installation.



# FIRE DOOR 9

## LVN25S NON-VISION FIRE + SMOKE AIR TRANSFER GRILLE INTO TIMBER FIRE DOOR

### DESCRIPTION

- 1 Minimum 50mm thick timber fire door
- 2 Steel or aluminium mounting flange
- 3 Horizontal intumescent louvred slats
- 4 Air transfer grille to door fasteners - 40mm wood screws
- 5 Hit + miss smoke control plates. Central plate moves, outer plates fixed
- 6 Servo driven actuator
- 7 Intumescent liner (LX5002 for 50mm thick doors or LX5402 for 54mm thick doors) between the air transfer grille and the door
- 8 Drop seal (optional)

In order to comply with CF564, the upper edge of the grille shall be no higher than 800mm from floor level. Consult door manufacturer before cutting out in relation to permissible aperture sizes and locations

If the door leaf core does not comprise a solid timber lamel core (i.e. a core of chipboard, flaxboard etc.), the aperture provided in the leaf should be lined to full width using hardwood, with a minimum density of 650kg/m<sup>3</sup> and a thickness of at least 6mm. This hardwood liner may be omitted should the leaf have been tested.

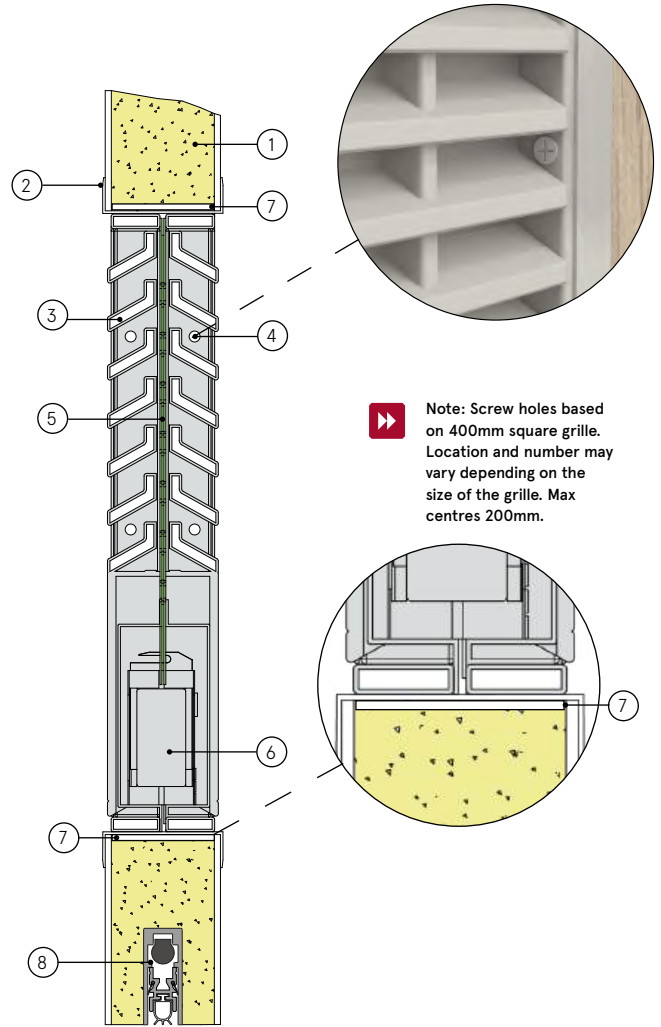

**Note:** Screw holes based on 400mm square grille. Location and number may vary depending on the size of the grille. Max centres 200mm.

### CONTENTS

- LVN25S fire + smoke resistant air transfer grille

- Lorient intumescent liner (LX5002/LX5402)
- Mounting flange
- Wiring instructions

### TOOLS REQUIRED

- 40mm wood screws
- Power drill
- Screw driver

### LVN25S into a timber fire door

### FD30S

### Fire Resistance in accordance with

BS 476-22:1987

### Approval Ref

CF564

### Max single cell size

400x400mm / 0.16m<sup>2</sup> at up to 800mm above FFL

Requires an aperture 9mm over size. e.g. a 300mm x 300mm needs an aperture 309mm x 309mm to accommodate the flange.

### INSTALLATION INSTRUCTIONS

- ▶ Ensure that cutting an aperture in the door will not detract from the fire integrity of the door. Contact the manufacturer to establish the maximum size and optimum position.
- ▶ The initial installation of this type of air transfer grille is best carried out with the door dismantled. If rebated threshold seal is to be fitted this should be done temporarily before fitting the LVN25S assembly and then removed.
- ▶ Cut the aperture to the required size with a maximum gap all around the outside of the flange of 9mm.
- ▶ Check that the two halves of the air transfer grille fit into the aperture without twisting jamming or in any way distorting. Remove LVN25S sub assemblies from aperture.
- ▶ Drill vertical outer frames of each air transfer grille and flange sub assembly to accept fixing screws if not pre-drilled when supplied.
- ▶ Drill and rebate door to provide wiring route to conductor hinges or loop connection (refer to conductor hinge datasheet).
- ▶ Fit intumescent liner (LX5002/LX5402) to the inside faces of the aperture.
- ▶ Fit the LVN25S sub assembly that incorporates the actuator into the aperture, ensuring that the actuator is at the bottom of the aperture. Route the wiring in to the required connection (hinge or loop) ensuring that it lies tidily and does not cause any distortion of the damper or is likely to become trapped.
- ▶ Fit retaining wood screws through pre-drilled holes in LVN25S vertical outer uprights into door.
- ▶ Refer to wiring instructions.
- ▶ Carry out a function check of the air transfer grille by activation from the control unit whilst actuator is visible and wiring accessible, before fitting the remaining half of the LVN25S.
- ▶ After satisfactorily completing function check, fit the remaining half LVN25S assembly ensuring that the smoke control sliding plates do not become squeezed between the two air transfer grille halves or wiring becomes trapped.
- ▶ Repeat the function check on complete installation.

# FIRE DOOR 10

## LVN25S NON-VISION FIRE + SMOKE AIR TRANSFER GRILLE INTO TIMBER FIRE DOOR

### DESCRIPTION

- |   |  |
|---|--|
| 1 | 54mm thick timber fire door  |
| 2 | Steel or aluminium flange  |
| 3 | Horizontal intumescent louvred slats                                     |
| 4 | Air transfer grille to door fasteners - 40mm wood screws                 |
| 5 | Hit + miss smoke control plates. Central plate moves, outer plates fixed |
| 6 | Servo driven actuator  |
| 7 | Intumescent liner (LX5402) between the air transfer grille and the door  |
| 8 | Drop seal (optional)   |

In order to comply with CF564, the upper edge of the grille shall be no higher than 800mm from floor level. Consult door manufacturer before cutting out in relation to permissible aperture sizes and locations

If the door leaf core does not comprise a solid timber lamel core (i.e. a core of chipboard, flaxboard etc.), the aperture provided in the leaf should be lined to full width using hardwood, with a minimum density of 650kg/m<sup>3</sup> and a thickness of at least 6mm. This hardwood liner may be omitted should the leaf have been tested.

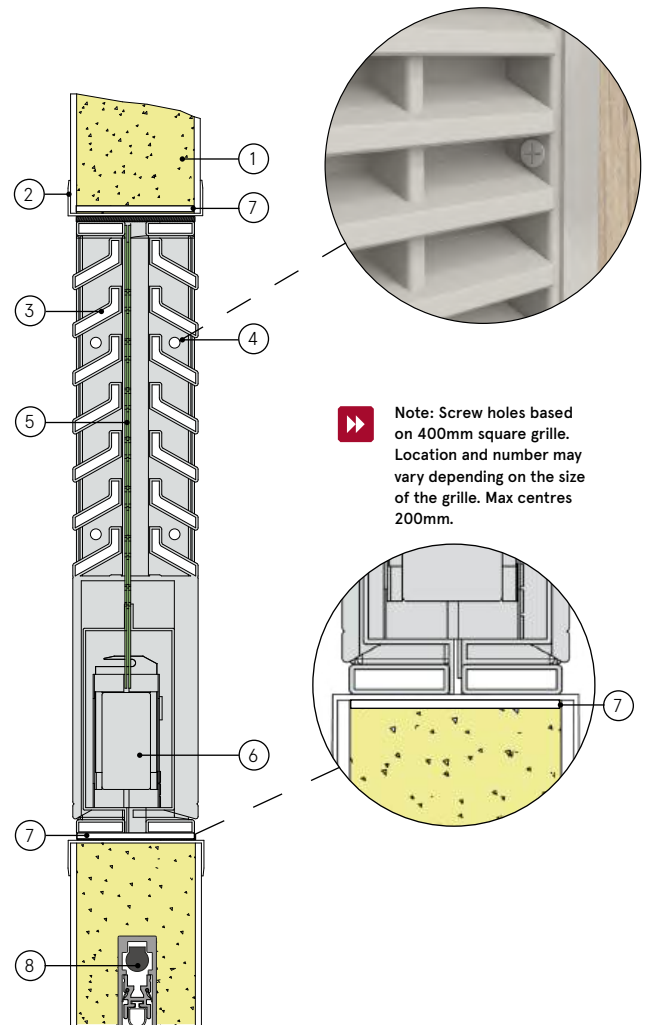

**Note:** Screw holes based on 400mm square grille. Location and number may vary depending on the size of the grille. Max centres 200mm.

### CONTENTS

- LVN25S fire + smoke resistant air transfer grille
- Lorient intumescent liner (LX5402)
- Mounting flange
- Wiring instructions

### TOOLS REQUIRED

- 40mm wood screws
- Power drill
- Screw driver

### LVN25S into a timber fire door

### FD60S

### Fire Resistance in accordance with

BS 476-22:1987

### Approval Ref

Applus-19-19940-1428\*  
CF564\*\*

### Max single cell size

350x350mm at up to 1350mm above FFL\*  
400x400mm / 0.16m<sup>2</sup> at up to 800mm above FFL\*\*  
0.16m<sup>2</sup>

Requires an aperture 9mm over size. e.g. a 300mm x 300mm needs an aperture 309mm x 309mm to accommodate the flange.

### INSTALLATION INSTRUCTIONS

- ▶ Ensure that cutting an aperture in the door will not detract from the fire integrity of the door. Contact the manufacturer to establish the maximum size and optimum position.
- ▶ The initial installation of this type of air transfer grille is best carried out with the door dismantled. If rebated threshold seal is to be fitted this should be done temporarily before fitting the LVN25S assembly and then removed.
- ▶ Cut the aperture to the required size with a maximum gap all around the outside of the flange of 9mm.
- ▶ Check that the two halves of the air transfer grille fit into the aperture without twisting jamming or in any way distorting. Remove LVN25S sub assemblies from aperture.
- ▶ Drill vertical outer frames of each air transfer grille and flange sub assembly to accept fixing screws if not pre-drilled when supplied.
- ▶ Drill and rebate door to provide wiring route to conductor hinges or loop connection (refer to conductor hinge datasheet).
- ▶ Fit intumescent liner (LX5402) to the inside faces of the aperture.
- ▶ Fit the LVN25S sub assembly that incorporates the actuator into the aperture, ensuring that the actuator is at the bottom of the aperture. Route the wiring in to the required connection (hinge or loop) ensuring that it lies tidily and does not cause any distortion of the damper or is likely to become trapped.
- ▶ Fit retaining wood screws through pre-drilled holes in LVN25S vertical outer uprights into door.
- ▶ **Refer to wiring instructions.**
- ▶ Carry out a function check of the air transfer grille by activation from the control unit whilst actuator is visible and wiring accessible, before fitting the remaining half of the LVN25S.
- ▶ After satisfactorily completing function check, fit the remaining half LVN25S assembly ensuring that the smoke control sliding plates do not become squeezed between the two air transfer grille halves or wiring becomes trapped.
- ▶ Repeat the function check on complete installation.



# FIRE DOOR 11

## LVH44 AIR TRANSFER GRILLE FITTED INTO TIMBER FRAME WITH ANGLE FIXINGS

### DESCRIPTION

- 1 Timber frame as part of associated doorset framing system
  - 2 Lorient intumescent sealant around LVH44 perimeter to a maximum clearance of 10mm
  - 3 Lorient LVH44 intumescent air transfer grille
  - 4 2mm intumescent liner
  - 5 **Fixing angle:** 20 x 20 x 1mm thick minimum galvanised steel angles fixed to air transfer grille unit with self tapping screws and to timber frame with wood screws
- Fixing option 1:** 20mm wide angle tabs, central to all four sides or at 200mm maximum centres
- Fixing option 2:** Full width angles top and bottom only with 200mm fixing centres

### CONTENTS

- LVH44 air transfer grille
- 2mm intumescent liner
- Cover grille (optional)

### TOOLS REQUIRED

- Angle fixings
- Self tapping screws (3.5 x 16mm)
- 25mm wood screws
- Lorient intumescent sealant

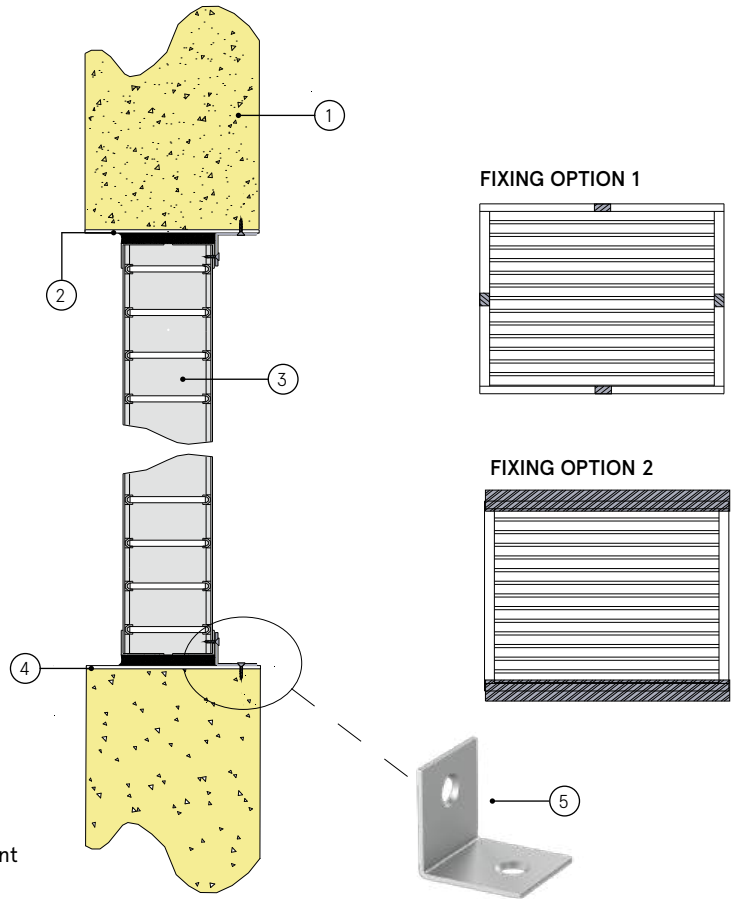

### LVH44 for timber frame with angle fixings

### FD30/FD60

### Fire Resistance in accordance with

BS 476-22:1987

### Approval Ref

WFRC C121316 (AW4T1)

### Max single cell size

Any rectangular shape up to 1200 x 600mm

LVH44 air transfer grilles are supplied 2mm less than the nominal size e.g. a 300mm x 300mm is actually 298mm x 298mm.

### INSTALLATION INSTRUCTIONS

- ▶ Apply Lorient intumescent liner to the inside faces of the aperture.
- ▶ Fix the mounting angles onto the LVH44 air transfer grille using self tapping screws to **one side only**.
- ▶ Insert LVH44 into timber frame. (Note: air transfer grille does not have to be centrally positioned in the opening).
- ▶ Fix the angles to the timber frame with wood screws.
- ▶ Apply a bead of Lorient intumescent sealant around the perimeter of LVH44 as shown (note: maximum clearance of 10mm applies).
- ▶ **Note: Fixings supplied by others.**

# FIRE DOOR 12

## LVH44 AIR TRANSFER GRILLE FITTED INTO TIMBER FRAME WITH TAB PLATE FIXINGS

### DESCRIPTION

- 1 Timber frame as part of associated doorset framing system
  - 2 Lorient intumescent sealant around air transfer grille perimeter to a maximum clearance of 10mm
  - 3 Lorient LVH44 intumescent air transfer grille
  - 4 2mm intumescent liner
  - 5 **Fixing tab:** 40 x 20 x 1mm thick minimum galvanised steel tabs fixed to LVH44 unit with self tapping screws and to timber frame with wood screws
- Fixing option 1:** 20mm wide tabs, central to all four sides or at 200mm maximum centres
- Fixing option 2:** Full width tabs top and bottom only with 200mm fixing centres

### CONTENTS

- LVH44 air transfer grille
- 2mm intumescent liner
- Cover grille (optional)

### TOOLS REQUIRED

- Tab plate fixings
- Self tapping screws (3.5 x 16mm)
- 25mm wood screws
- Lorient intumescent sealant

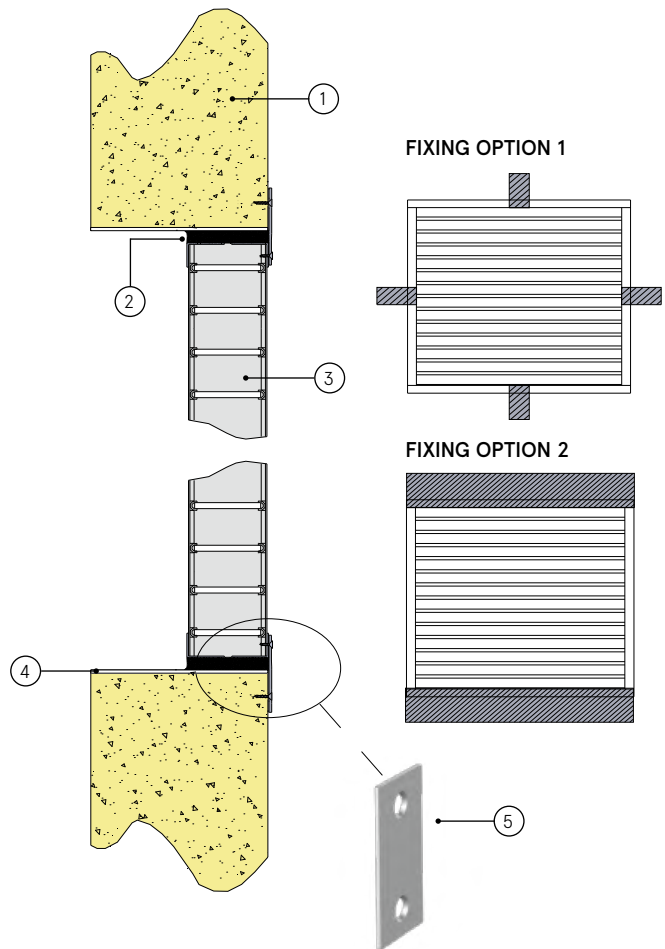

### LVH44 for timber frame with tab plate fixings

## FD30/FD60

### Fire Resistance in accordance with

BS 476-22:1987

### Approval Ref

WFRC C121316 (AW4T2)

### Max single cell size

Any rectangular shape up to 1200 x 600mm

LVH44 air transfer grilles are supplied 2mm less than the nominal size e.g. a 300mm x 300mm is actually 298mm x 298mm.

### INSTALLATION INSTRUCTIONS

- ▶ Apply Lorient intumescent liner to the inside faces of the aperture.
- ▶ Fix the mounting tabs onto the LVH44 air transfer grille using self tapping screws to **one side only**.
- ▶ Insert LVH44 into timber frame. (Note: air transfer grille does not have to be centrally positioned in the opening).
- ▶ Fix the tabs to the timber frame with wood screws.
- ▶ Apply a bead of Lorient intumescent sealant around the perimeter of LVH44 as shown (note: maximum clearance of 10mm applies).
- ▶ **Note: Fixings supplied by others.**

# FIRE DOOR 13

## LVH44 AIR TRANSFER GRILLE FITTED INTO TIMBER FRAME WITH Z SECTION FIXINGS

### DESCRIPTION

- 1 Timber frame as part of associated doorset framing system
- 2 Lorient intumescent sealant around LVH44 perimeter to a maximum clearance of 10mm
- 3 Lorient LVH44 intumescent air transfer grille
- 4 **Fixing Z section:** 40 x 20 x 1mm thick minimum galvanised steel Z section fixed to LVH44 with self tapping screws and to timber frame with wood screws

**Fixing option 1:** 20mm wide tabs, central to all four sides or at 200mm maximum centres

**Fixing option 2:** Full width tabs top and bottom only with 200mm fixing centres.

### CONTENTS

- LVH44 air transfer grille
- 2mm intumescent liner
- Cover grille (optional)

### TOOLS REQUIRED

- Z section fixings
- Self tapping screws (3.5 x 16mm)
- 25mm wood screws
- Lorient intumescent sealant

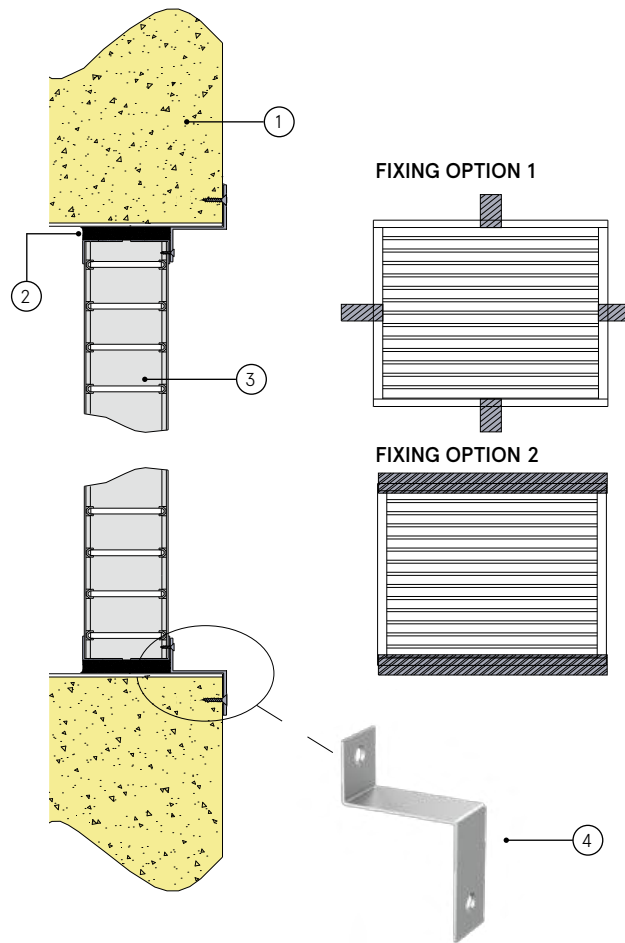

### LVH44 for timber frame with Z section fixings

#### FD30/FD60

#### Fire Resistance in accordance with

BS 476-22:1987

#### Approval Ref

WFRC C121316 (AW4T3)

#### Max single cell size

Any rectangular shape up to 1200 x 600mm

LVH44 air transfer grilles are supplied 2mm less than the nominal size e.g. a 300mm x 300mm is actually 298mm x 298mm.

### INSTALLATION INSTRUCTIONS

- ▶ Apply Lorient intumescent liner to the inside faces of the aperture.
- ▶ Fix the mounting Z section onto the LVH44 air transfer grille using self tapping screws to **one side only**.
- ▶ Insert LVH44 into timber frame. (Note: air transfer grille does not have to be centrally positioned in the opening).
- ▶ Fix the Z section to the timber frame with wood screws.
- ▶ Apply a bead of Lorient intumescent sealant around the perimeter of LVH44 as shown (note: maximum clearance of 10mm applies).
- ▶ **Note: Fixings supplied by others.**

# FIRE DOOR 14

## LVH44 AIR TRANSFER GRILLE FITTED INTO STEEL FRAME WITH ANGLE FIXINGS

### DESCRIPTION

- 1 Steel frame as part of associated doorset framing system
  - 2 Lorient intumescent sealant around LVH44 perimeter to a maximum clearance of 10mm
  - 3 Lorient LVH44 intumescent air transfer grille
  - 4 4mm intumescent liner
  - 5 **Fixing angle:** 20 x 20 x 1mm thick minimum galvanised steel angles fixed to air transfer grille unit with self tapping screws and to steel frame with self tapping screws
- Fixing option 1:** 20mm wide angle tabs, central to all four sides or at 200mm maximum centres
- Fixing option 2:** Full width angles top and bottom only with 200mm fixing centres

### CONTENTS

- LVH44 air transfer grille
- 4mm graphite liner
- Cover grille (optional)

### TOOLS REQUIRED

- Angle fixings
- Self tapping screws (3.5 x 16mm)
- Lorient intumescent sealant

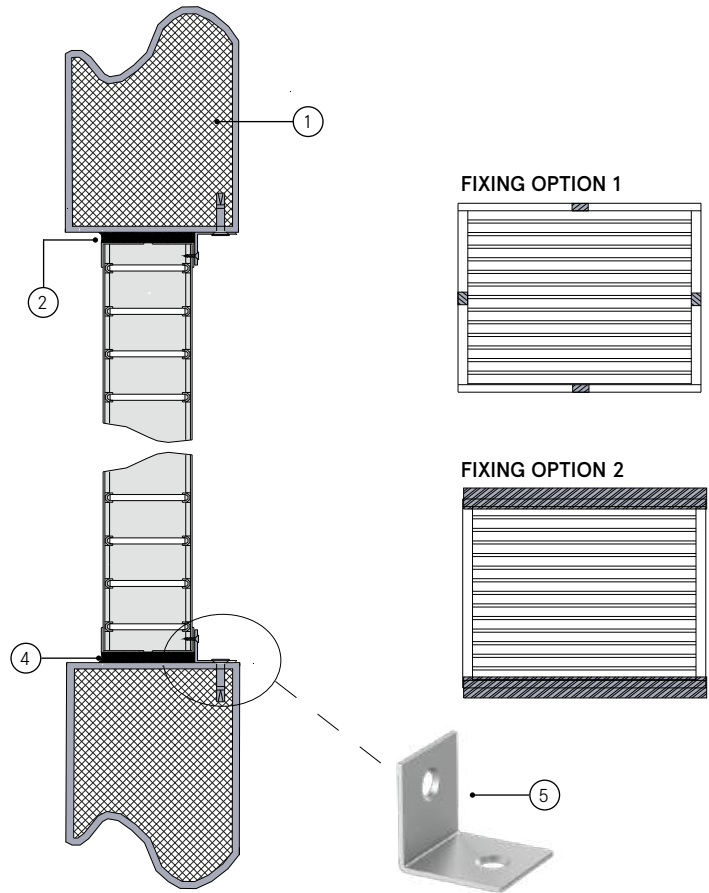

### LVH44 for steel frame with angle fixings

#### FD120

#### Fire Resistance in accordance with

BS 476-22:1987

#### Approval Ref

WFRC C121316 (AW4S1)

#### Max single cell size

Any rectangular shape up to 1200 x 600mm

LVH44 air transfer grilles are supplied 2mm less than the nominal size e.g. a 300mm x 300mm is actually 298mm x 298mm.

### INSTALLATION INSTRUCTIONS

- ▶ Apply Lorient intumescent liner to the inside faces of the aperture.
- ▶ Fix the mounting angles onto the LVH44 air transfer grille using self tapping screws to **one side only**.
- ▶ Insert LVH44 into steel frame. (Note: air transfer grille does not have to be centrally positioned in the opening).
- ▶ Fix the angles to the steel frame with self tapping screws.
- ▶ Apply a bead of Lorient intumescent sealant around the perimeter of LVH44 as shown (note: maximum clearance of 10mm applies).
- ▶ **Note: Fixings supplied by others.**

# FIRE DOOR 15

## LVH44 AIR TRANSFER GRILLE FITTED INTO STEEL FRAME WITH TAB PLATE FIXINGS

### DESCRIPTION

- 1 Steel frame as part of associated doorset framing system
- 2 Lorient intumescent sealant around air transfer grille perimeter to a maximum clearance of 10mm
- 3 Lorient LVH44 intumescent air transfer grille
- 4 4mm intumescent liner
- 5 **Fixing tab:** 40 x 20 x 1mm thick minimum galvanised steel tabs fixed to LVH44 unit with self tapping screws and to steel frame with self tapping screws

**Fixing option 1:** 20mm wide tabs, central to all four sides or at 200mm maximum centres

**Fixing option 2:** Full width tabs top and bottom only with 200mm fixing centres

### CONTENTS

- LVH44 air transfer grille
- 4mm graphite liner
- Cover grille (optional)

### TOOLS REQUIRED

- Tab plate fixings
- Self tapping screws (3.5 x 16mm)
- Lorient intumescent sealant

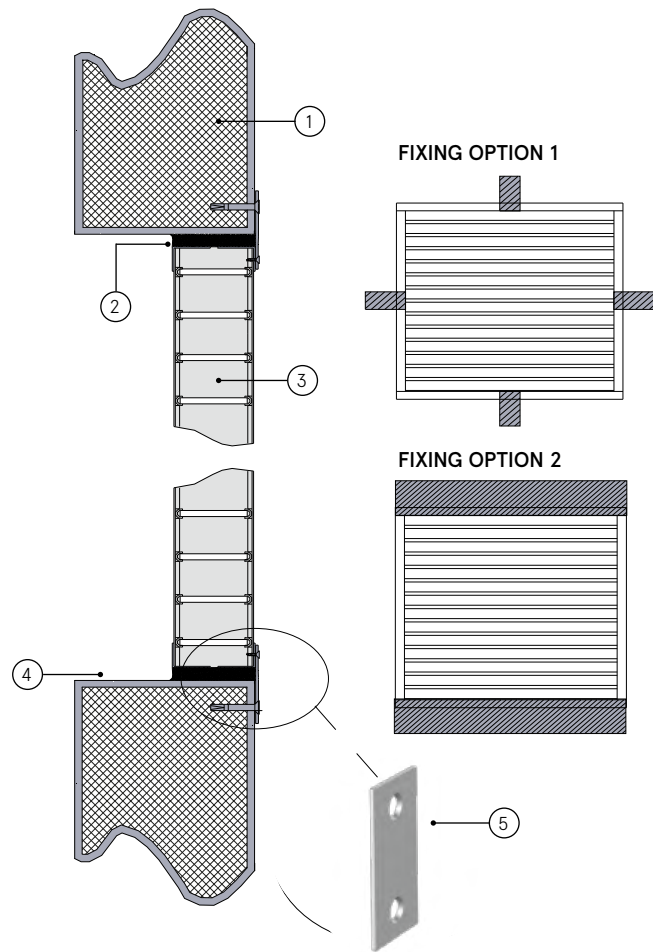

### LVH44 for steel frame with tab plate fixings

## FD120

### Fire Resistance in accordance with

BS 476-22:1987

### Approval Ref

WFRC C121316 (AW4S2)

### Max single cell size

Any rectangular shape up to 1200 x 600mm

LVH44 air transfer grilles are supplied 2mm less than the nominal size e.g. a 300mm x 300mm is actually 298mm x 298mm.

### INSTALLATION INSTRUCTIONS

- ▶ Apply Lorient intumescent liner to the inside faces of the aperture.
- ▶ Fix the mounting tabs onto the LVH44 air transfer grille using self tapping screws to **one side only**.
- ▶ Insert LVH44 into steel frame. (Note: air transfer grille does not have to be centrally positioned in the opening).
- ▶ Fix the tabs to the steel frame with self tapping screws.
- ▶ Apply a bead of Lorient intumescent sealant around the perimeter of LVH44 as shown (note: maximum clearance of 10mm applies).
- ▶ **Note: Fixings supplied by others.**

# FIRE DOOR 16

## LVH44 AIR TRANSFER GRILLE FITTED INTO STEEL FRAME WITH Z SECTION FIXINGS

### DESCRIPTION

- 1 Steel frame as part of associated doorset framing system
  - 2 Lorient intumescent sealant around LVH44 perimeter to a maximum clearance of 10mm
  - 3 Lorient LVH44 intumescent air transfer grille
  - 4 4mm intumescent liner
  - 5 **Fixing Z section:** 40 x 20 x 1mm thick minimum galvanised steel Z section fixed to LVH44 with self tapping screws and to steel frame with self tapping screws
- Fixing option 1:** 20mm wide tabs, central to all four sides or at 200mm maximum centres
- Fixing option 2:** Full width tabs top and bottom only with 200mm fixing centres.

### CONTENTS

- LVH44 air transfer grille
- 4mm graphite liner
- Cover grille (optional)

### TOOLS REQUIRED

- Z section fixings
- Self tapping screws (3.5 x 16mm)
- Lorient intumescent sealant

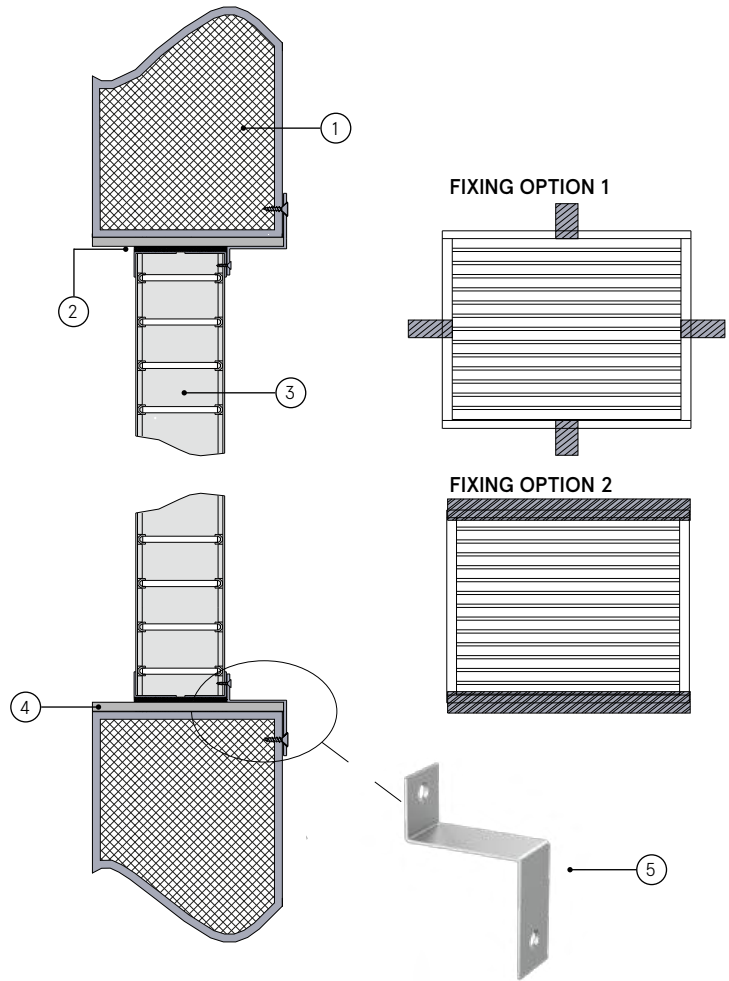

### LVH44 for steel frame with Z section fixings

## FD120

### Fire Resistance in accordance with

BS 476-22:1987

### Approval Ref

WFRC C121316 (AW4S3)

### Max single cell size

Any rectangular shape up to 1200 x 600mm

LVH44 air transfer grilles are supplied 2mm less than the nominal size e.g. a 300mm x 300mm is actually 298mm x 298mm.

### INSTALLATION INSTRUCTIONS

- ▶ Apply Lorient intumescent liner to the inside faces of the aperture.
- ▶ Fix the mounting Z section onto the LVH44 air transfer grille using self tapping screws to **one side only**.
- ▶ Insert LVH44 into steel frame. (Note: air transfer grille does not have to be centrally positioned in the opening).
- ▶ Fix the Z section to the steel frame with self tapping screws.
- ▶ Apply a bead of Lorient intumescent sealant around the perimeter of LVH44 as shown (note: maximum clearance of 10mm applies).
- ▶ **Note: Fixings supplied by others.**

# WALL MOUNTED SYSTEMS

Fitted into walls, our intumescent air transfer grilles and fire dampers combine air movement with fire protection. They provide a cost effective solution in allowing free air movement and yet maintain the integrity of the wall in a fire situation.

System		Fire Rating	Application	Product	Certifire	Page No.
Wall 1	▲	FR120	Rigid wall with angle fixings	<b>LVH44</b>	CF564	<b>30</b>
Wall 2	▲	FR120	Rigid wall with tab plate fixings	<b>LVH44</b>	CF564	<b>31</b>
Wall 3	▲	FR120	Rigid wall with Z section fixings	<b>LVH44</b>	CF564	<b>32</b>
Wall 4	▲	FR120	Fire rated flexible wall with angle fixings	<b>LVH44</b>	-	<b>33</b>
Wall 5	▲	FR120	Fire rated flexible wall with tab plate fixings	<b>LVH44</b>	-	<b>34</b>
Wall 6	▲	FR120	Fire rated flexible wall with Z section fixings	<b>LVH44</b>	-	<b>35</b>
Wall 7	▲	FR120	Face fixed onto rigid wall with angle fixings	<b>LVH44</b>	-	<b>36</b>
Wall 8	▲	FR120	Modular systems for rigid wall with angle fixings	<b>LVH44</b>	-	<b>37</b>
Wall 9	▲	FR120	Modular systems for rigid wall with Z section fixings	<b>LVH44</b>	-	<b>38</b>
Wall 11	▲	EI90/EI120	Rigid wall construction	<b>LVH44</b>	-	<b>40</b>
Wall 12	▲	FR60	Rigid wall construction	<b>LVV40</b>	CF564	<b>41</b>
Wall 13	▲	FR60	Rigid wall construction	<b>LVC40</b>	CF564	<b>42</b>
Wall 14	▲	EI120	Rigid wall construction	<b>LVV40</b>	-	<b>43</b>
Wall 15	▲	EI60	Fire rated flexible wall	<b>LVV40</b>	-	<b>44</b>
Wall 16	▲ ▲	EI60S/FR90S*	Rigid wall construction	<b>LVV40S</b>	*CF564	<b>45</b>
Wall 17	▲ ▲	EI60S	Fire rated flexible wall	<b>LVV40S</b>	-	<b>46</b>
Wall 18	▲ ▲	FR120S	Rigid wall construction	<b>LVH44S</b>	-	<b>47</b>
Wall 19	▲ ▲	FR120S	Fire rated flexible wall	<b>LVH44S</b>	-	<b>48</b>

# WALL 1

## LVH44 AIR TRANSFER GRILLE FITTED INTO RIGID WALL WITH ANGLE FIXINGS

### DESCRIPTION

- 1 Rigid wall construction
- 2 Lorient intumescent sealant around LVH44 perimeter to a maximum clearance of 25mm
- 3 Lorient LVH44 intumescent air transfer grille
- 4 **Fixing angle:** 20 x 20 x 1mm thick minimum galvanised steel angles fixed to air transfer grille unit with self tapping screws and to wall with masonry anchors

**Fixing option 1:** 20mm wide angle tabs, central to all four sides or at 200mm maximum centres

**Fixing option 2:** Full width angles top and bottom only with 200mm fixing centres

In order to comply with CF564, the upper edge of the grille shall be no higher than 3000mm from floor level. The lower edge of the grille shall be no closer than 200mm to floor level.

### CONTENTS

- LVH44 air transfer grille
- Cover grille (optional)

### TOOLS REQUIRED

- Angle fixings
- Self tapping screws (3.5 x 16mm)
- Masonry anchors
- Lorient intumescent sealant

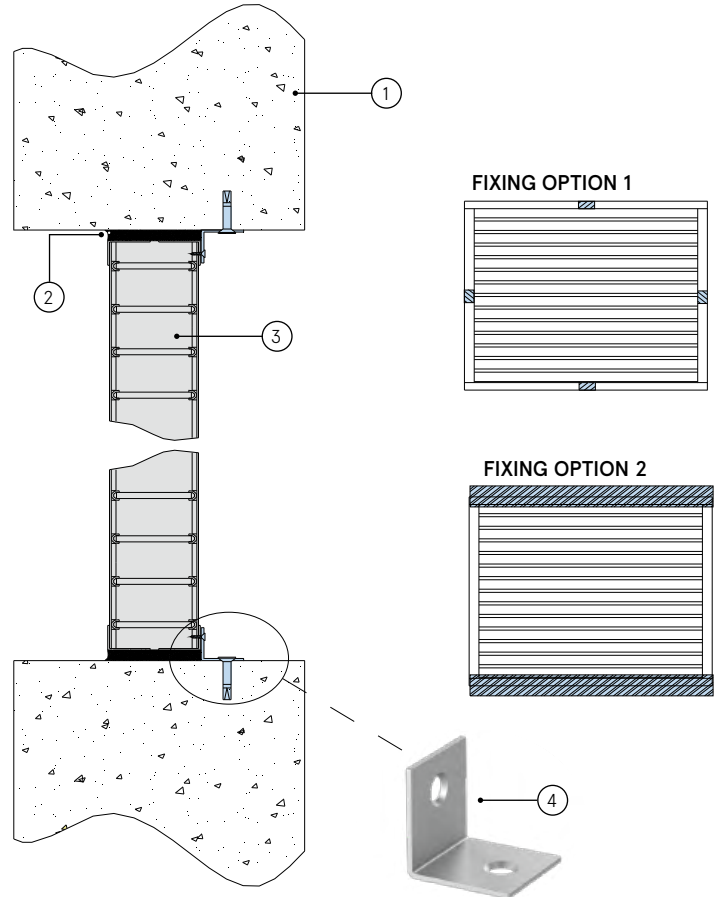

### LVH44 for rigid wall with angle fixings

## FR120

### Fire Resistance in accordance with

BS 476-22:1987

### Approval Ref

WFRC C121316 (AW1)  
CF564\*

### Max single cell size

Any rectangular shape up to 600 x 600mm  
\*0.2025m<sup>2</sup>

LVH44 air transfer grilles are supplied 2mm less than the nominal size e.g. a 300mm x 300mm is actually 298mm x 298mm.

### INSTALLATION INSTRUCTIONS

- ▶ Fix the mounting angles onto the LVH44 air transfer grille using self tapping screws to **one side only**.
- ▶ Insert LVH44 into rigid wall opening. (Note: air transfer grille does not have to be centrally positioned in the opening).
- ▶ Fix the angles to the rigid wall with masonry anchors.
- ▶ Apply a bead of Lorient intumescent sealant to full depth around the perimeter of LVH44 as shown (note: maximum clearance of 25mm applies).
- ▶ Connect ductwork (or cover grille) directly to wall using approved breakaway connections to ensure compliance.
- ▶ **Note: Fixings supplied by others.**



# WALL 2

## LVH44 AIR TRANSFER GRILLE FITTED INTO RIGID WALL WITH TAB PLATE FIXINGS

### DESCRIPTION

- 1 Rigid wall construction
- 2 Lorient intumescent sealant around air transfer grille perimeter to a maximum clearance of 25mm
- 3 Lorient LVH44 intumescent air transfer grille
- 4 **Fixing tab:** 40 x 20 x 1mm thick minimum galvanised steel tabs fixed to LVH44 unit with self tapping screws and to wall with masonry anchors

**Fixing option 1:** 20mm wide tabs, central to all four sides or at 200mm maximum centres

**Fixing option 2:** Full width tabs top and bottom only with 200mm fixing centres

In order to comply with CF564, the upper edge of the grille shall be no higher than 3000mm from floor level. The lower edge of the grille shall be no closer than 200mm to floor level.

### CONTENTS

- LVH44 air transfer grille
- Cover grille (optional)

### TOOLS REQUIRED

- Tab plate fixings
- Self tapping screws (3.5 x 16mm)
- Lorient intumescent sealant

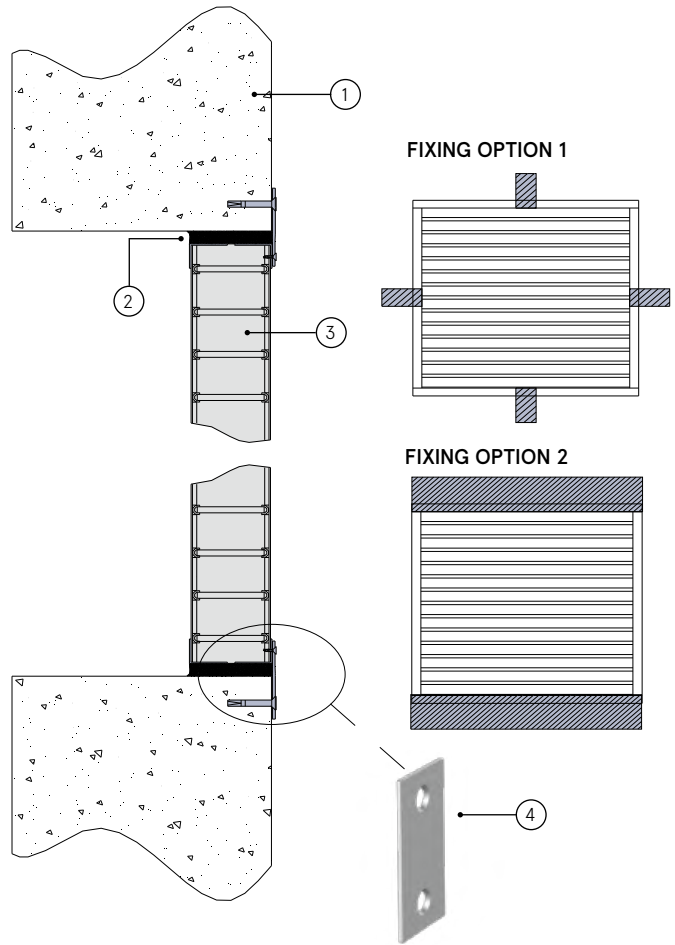

### LVH44 for rigid wall with tab plate fixings

## FR120

### Fire Resistance in accordance with

BS 476-22:1987

### Approval Ref

WFRC C121316 (AW2)  
CF564\*

### Max single cell size

Any rectangular shape up to 600 x 600mm  
0.2025m<sup>2</sup>\*

LVH44 air transfer grilles are supplied 2mm less than the nominal size e.g. a 300mm x 300mm is actually 298mm x 298mm.

### INSTALLATION INSTRUCTIONS

- ▶ Fix the mounting tabs onto the LVH44 air transfer grille using self tapping screws to **one side only**.
- ▶ Insert LVH44 into rigid wall opening. (Note: air transfer grille does not have to be centrally positioned in the opening).
- ▶ Fix the tabs to the rigid wall with masonry anchors.
- ▶ Apply a bead of Lorient intumescent sealant to full depth around the perimeter of LVH44 as shown (note: maximum clearance of 25mm applies).
- ▶ Connect ductwork (or cover grille) directly to wall using approved breakaway connections to ensure compliance.
- ▶ **Note: Fixings supplied by others.**

# WALL 3

## LVH44 INTO RIGID WALL WITH Z SECTION FIXINGS

### DESCRIPTION

- 1 Rigid wall construction
- 2 Lorient intumescent sealant around LVH44 perimeter to a maximum clearance of 25mm
- 3 Lorient LVH44 intumescent air transfer grille
- 4 **Fixing Z section:** 40 x 20 x 1mm thick minimum galvanised steel Z section fixed to LVH44 with self tapping screws and to wall with masonry anchors

**Fixing option 1:** 20mm wide tabs, central to all four sides or at 200mm maximum centres

**Fixing option 2:** Full width tabs top and bottom only with 200mm fixing centres.

In order to comply with CF564, the upper edge of the grille shall be no higher than 3000mm from floor level. The lower edge of the grille shall be no closer than 200mm to floor level.

### CONTENTS

- LVH44 air transfer grille
- Cover grille (optional)

### TOOLS REQUIRED

- Z section fixings
- Self tapping screws (3.5 x 16mm)
- Masonry anchors
- Lorient intumescent sealant

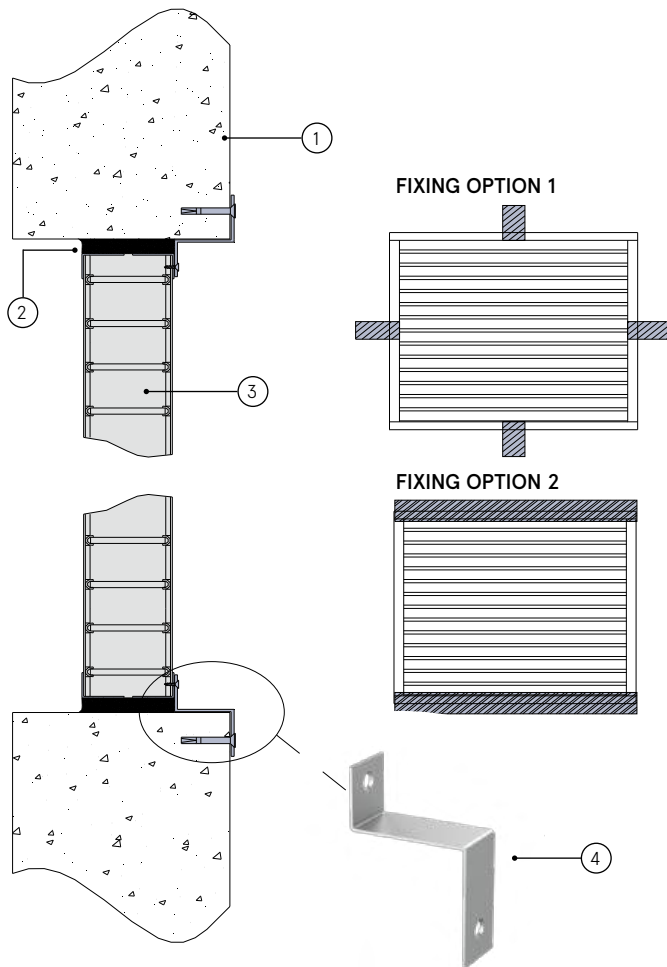

### LVH44 for rigid wall with Z section fixings

## FR120

### Fire Resistance in accordance with

BS 476-22:1987

### Approval Ref

WFRC C121316 (AW3)  
CF564\*

### Max single cell size

Any rectangular shape up to 600 x 600mm  
0.2025m<sup>2</sup>\*

LVH44 air transfer grilles are supplied 2mm less than the nominal size e.g. a 300mm x 300mm is actually 298mm x 298mm.

### INSTALLATION INSTRUCTIONS

- ▶ Fix the mounting Z section onto the LVH44 air transfer grille using self tapping screws to **one side only**.
- ▶ Insert LVH44 into rigid wall opening. (Note: air transfer grille does not have to be centrally positioned in the opening).
- ▶ Fix the Z section to the rigid wall with masonry anchors.
- ▶ Apply a bead of Lorient intumescent sealant to full depth around the perimeter of LVH44 as shown (note: maximum clearance of 25mm applies).
- ▶ Connect ductwork (or cover grille) directly to wall using approved breakaway connections to ensure compliance.
- ▶ **Note: Fixings supplied by others.**

# WALL 4

## LVH44 INTO FIRE RATED FLEXIBLE WALL WITH ANGLE FIXINGS

### DESCRIPTION

- 1 Fire rated flexible wall
  - 2 Lorient intumescent sealant around LVH44 perimeter to a maximum clearance of 25mm
  - 3 Lorient LVH44 intumescent air transfer grille
  - 4 **Fixing angle:** 20 x 20 x 1mm thick minimum galvanised steel angles fixed to LVH44 with self tapping screws and to wall with drywall screws
- Fixing option 1:** 20mm wide angles, central to all four sides or at 200mm maximum centres
- Fixing option 2:** Full width angles top and bottom only with 200mm fixing centres.

### CONTENTS

- LVH44 air transfer grille
- Cover grille (optional)

### TOOLS REQUIRED

- Angle fixings
- Self tapping screws (3.5 x 16mm)
- Drywall screws
- Lorient intumescent sealant

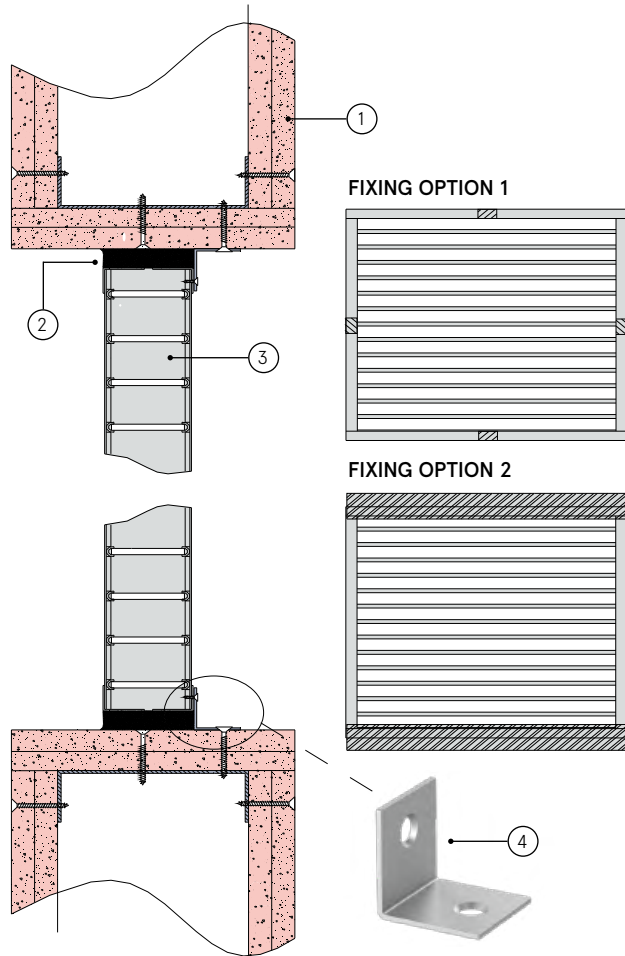

### LVH44 for FR flexible wall with angle fixings

## FR60 / FR120

### Fire Resistance in accordance with

BS 476-22:1987

### Approval Ref

FSP 1970

FRT 230055

### Max single cell size

600mm x 600mm

LVH44 air transfer grilles are supplied 2mm less than the nominal size e.g. a 300mm x 300mm is actually 298mm x 298mm.

### INSTALLATION INSTRUCTIONS

- ▶ Fix the mounting angles onto the LVH44 air transfer grille using self tapping screws to **one side only**.
- ▶ Insert LVH44 into fire rated flexible wall opening. (Note: air transfer grille does not have to be centrally positioned in the opening).
- ▶ Fix the angle to the fire rated flexible wall with drywall screws.
- ▶ Apply a bead of Lorient intumescent sealant to full depth around the perimeter of LVH44 as shown (Note: maximum clearance of 25mm applies).
- ▶ Connect ductwork (or cover grille) directly to wall using approved breakaway connections to ensure compliance.
- ▶ **Note: Fixings supplied by others.**

# WALL 5

## LVH44 INTO FIRE RATED FLEXIBLE WALL WITH TAB PLATE FIXINGS

### DESCRIPTION

- 1 Fire rated flexible wall
  - 2 Lorient intumescent sealant around LVH44 perimeter to a maximum clearance of 25mm
  - 3 Lorient LVH44 intumescent air transfer grille
  - 4 **Fixing tab:** 40 x 20 x 1mm thick minimum galvanised steel tabs fixed to LVH44 with self tapping screws and to wall with drywall screws
- Fixing option 1:** 20mm wide tabs, central to all four sides or at 200mm maximum centres
- Fixing option 2:** Full width tabs top and bottom only with 200mm fixing centres.

### CONTENTS

- LVH44 air transfer grille
- Cover grille (optional)

### TOOLS REQUIRED

- Steel tabs
- Self tapping screws (3.5 x 16mm)
- Drywall screws
- Lorient intumescent sealant

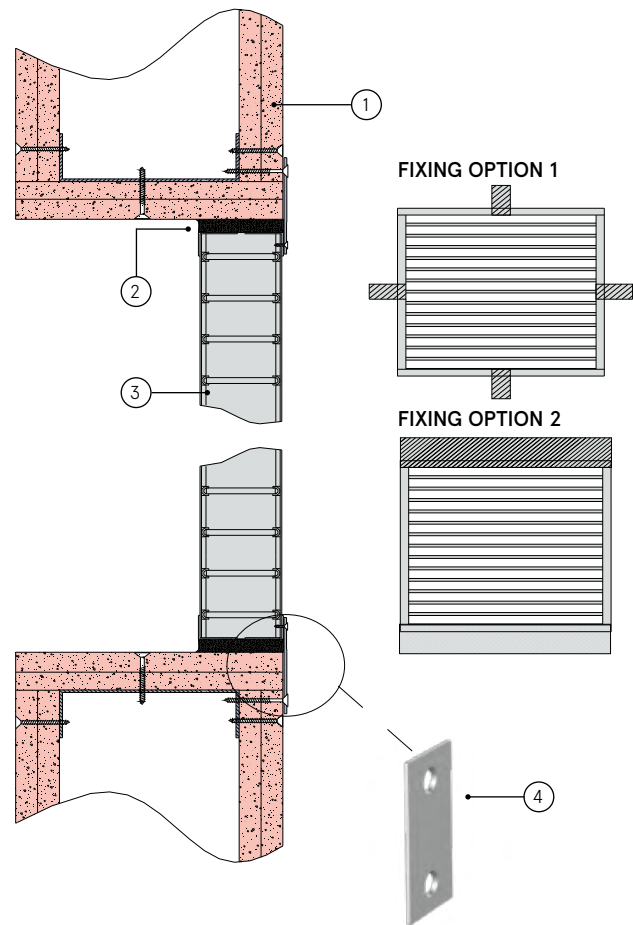

### LVH44 for FR flexible wall with tab fixings

## FR60 / FR120

### Fire Resistance in accordance with

BS 476-22:1987

### Approval Ref

FSP 1970

FRT 230055

### Max single cell size

600mm x 600mm

LVH44 air transfer grilles are supplied 2mm less than the nominal size e.g. a 300mm x 300mm is actually 298mm x 298mm.

### INSTALLATION INSTRUCTIONS

- ▶ Fix the mounting tabs onto the LVH44 air transfer grilles using self tapping screws to **one side only**.
- ▶ Insert LVH44 into fire rated flexible wall opening. (Note: air transfer grille does not have to be centrally positioned in the opening).
- ▶ Fix the tab to the fire rated flexible wall with drywall screws.
- ▶ Apply a bead of Lorient intumescent sealant to full depth around the perimeter of LVH44 as shown (Note: maximum clearance of 25mm applies).
- ▶ Connect ductwork (or cover grille) directly to wall using approved breakaway connections to ensure compliance.
- ▶ **Note: Fixings supplied by others.**

# WALL 6

## LVH44 INTO FIRE RATED FLEXIBLE WALL WITH Z SECTION FIXINGS

### DESCRIPTION

- 1 Fire rated flexible wall
- 2 Lorient intumescent sealant around LVH44 perimeter to a maximum clearance of 25mm
- 3 Lorient LVH44 intumescent air transfer grille
- 4 **Fixing Z section:** 40 x 20 x 1mm thick minimum galvanised steel Z section fixed to LVH44 with self tapping screws and to wall with drywall screws

**Fixing option 1:** 20mm wide angles, central to all four sides or at 200mm maximum centres

**Fixing option 2:** Full width angles top and bottom only with 200mm fixing centres.

### CONTENTS

- LVH44 air transfer grille
- Cover grille (optional)

### TOOLS REQUIRED

- Z section fixings
- Self tapping screws (3.5 x 16mm)
- Drywall screws
- Lorient intumescent sealant

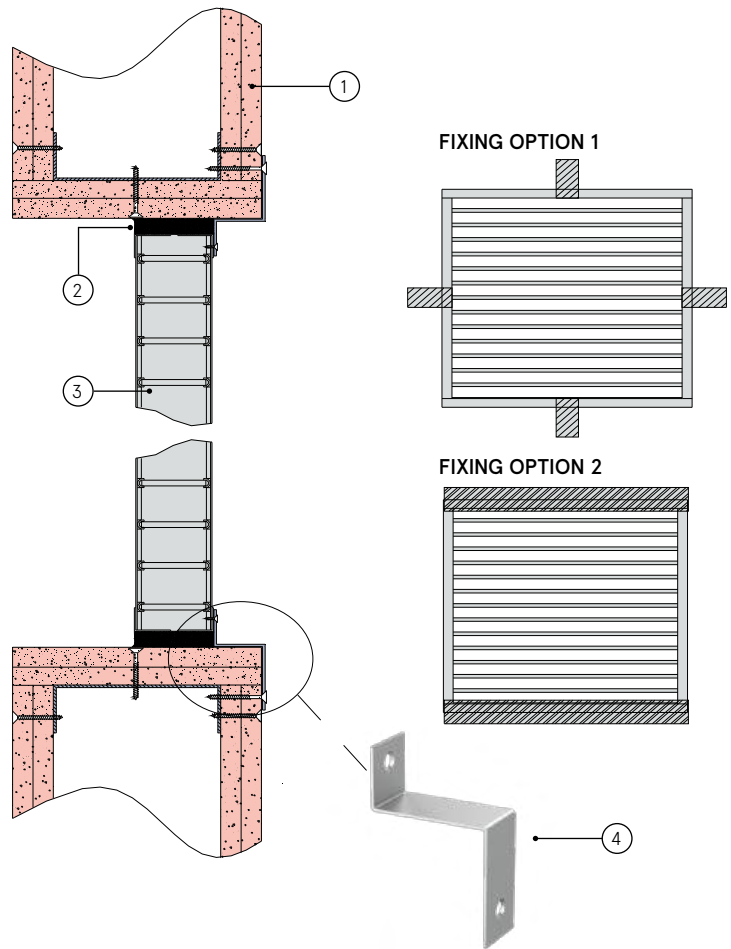

### LVH44 for FR flexible wall with Z section fixings

## FR60 / FR120

### Fire Resistance in accordance with

BS 476-22:1987

### Approval Ref

FSP 1970

FRT 230055

### Max single cell size

600mm x 600mm

LVH44 air transfer grilles are supplied 2mm less than the nominal size e.g. a 300mm x 300mm is actually 298mm x 298mm.

### INSTALLATION INSTRUCTIONS

- ▶ Fix the Z sections onto the LVH44 air transfer grille using self tapping screws to **one side only**.
- ▶ Insert LVH44 into fire rated flexible wall opening. (Note: air transfer grille does not have to be centrally positioned in the opening).
- ▶ Fix the Z section to the fire rated flexible wall with drywall screws.
- ▶ Apply a bead of Lorient intumescent sealant to full depth around the perimeter of LVH44 as shown (Note: maximum clearance of 25mm applies).
- ▶ Connect ductwork (or cover grille) directly to wall using approved breakaway connections to ensure compliance.
- ▶ **Note: Fixings supplied by others.**

# WALL 7

## LVH44 FACE-FIXED ONTO RIGID WALL WITH ANGLE FIXINGS

### DESCRIPTION

- 1 Rigid wall construction
  - 2 Lorient intumescent sealant between air transfer grille and masonry wall
  - 3 Lorient LVH44 intumescent air transfer grille to one side only (either side of the wall is acceptable)
  - 4 **Fixing angle:** 40 x 40 x 1mm thick minimum galvanised steel angles fixed to LVH44 unit with self tapping screws and to wall with masonry anchors
- Fixing option 1:** 20mm wide angles, central to all four sides or at 200mm maximum centres
- Fixing option 2:** Full width angles top and bottom only with 200mm fixing centres.

### CONTENTS

- LVH44 air transfer grille
- Cover grille (optional)

### TOOLS REQUIRED

- Steel angles
- Self tapping screws (3.5 x 16mm)
- Masonry anchors
- Lorient intumescent sealant

**Note:** Maximum size for surface method 600mm x 600mm

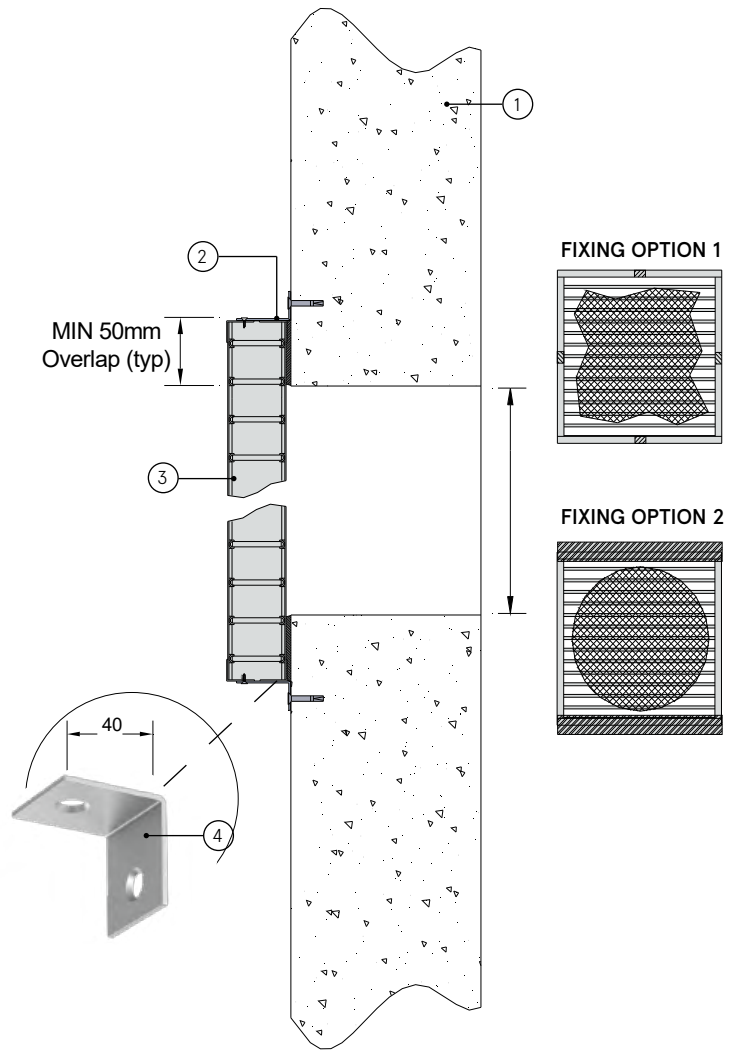

### LVH44 for rigid wall face fixed and angle fixings

#### FR120

#### Fire Resistance in accordance with

BS 476-22:1987

#### Approval Ref

WFRC 121316 (AW7)

#### Max size for surface mounted method

600mm x 600mm

LVH44 air transfer grilles are supplied 2mm less than the nominal size e.g. a 300mm x 300mm is actually 298mm x 298mm.

### INSTALLATION INSTRUCTIONS

- ▶ Measure penetration ensuring air transfer grille provides 50mm of overlap.
- ▶ Fix the mounting angles onto the LVH44 air transfer grille using self tapping screws.
- ▶ Mount air transfer grille onto rigid wall opening.
- ▶ Fix the angles to the rigid wall with masonry anchors.
- ▶ Apply a bead of Lorient intumescent sealant around the perimeter of air transfer grille between the LVH44 and the wall.
- ▶ Connect ductwork (or cover grille) directly to wall using approved breakaway connections to ensure compliance.
- ▶ **Note:** Fixings supplied by others.

# WALL 8

## LVH44 MODULAR SYSTEM FOR RIGID WALLS WITH ANGLE FIXINGS

### DESCRIPTION

- 1 Rigid wall construction
- 2 Lorient LVH44 intumescent air transfer grille
- 3 Lorient intumescent sealant around LVH44 perimeter to a maximum clearance of 25mm
- 4 **Fixing angle:** Full width galvanised steel angles (20 x 20 x 1mm) around perimeter of LVH44 on both sides with 200mm fixing centres
- 5 Air transfer grilles slot together using tab system

**Note:** For modular systems a 10mm (min) clearance around perimeter is needed

### CONTENTS

- LVH44 air transfer grille
- Cover grille (optional)

### TOOLS REQUIRED

- Steel angles
- Self tapping screws (3.5 x 16mm)
- Masonry anchors
- Lorient intumescent sealant

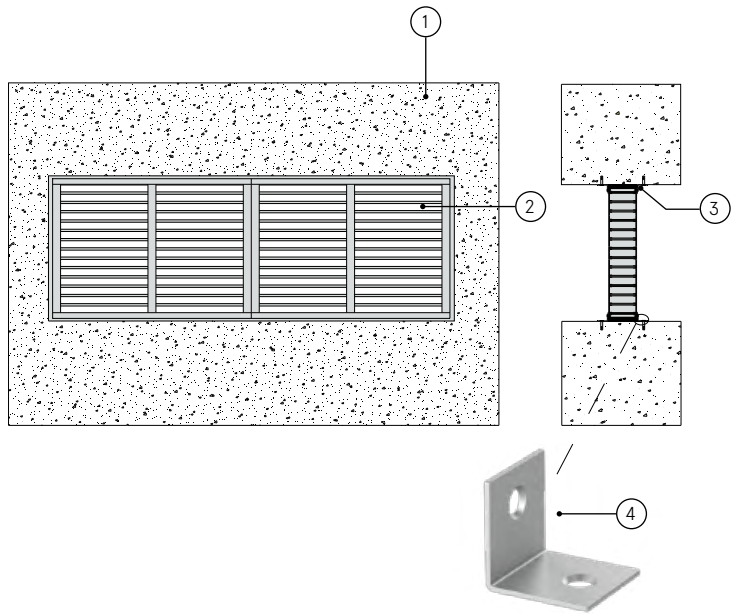

### LVH44 for rigid wall modular systems with angle fixings

#### FR120

#### Fire Resistance in accordance with

BS 476-22:1987

#### Approval Ref

WFRC 121316 (AW8)

#### Max size.

1800mm x 600mm

Larger sizes can be used with a different mounting detail.

LVH44 air transfer grilles are supplied 2mm less than the nominal size e.g. a 300mm x 300mm is actually 298mm x 298mm.

### INSTALLATION INSTRUCTIONS

- ▶ Slide the LVH44 modules together ensuring a bead of Lorient intumescent sealant is used in between air transfer grille modules.
- ▶ Secure tab with self tapping screws into LVH44.
- ▶ Fix the mounting angles onto the LVH44 using self tapping screws to **both sides of the modular air transfer grille.**
- ▶ Insert modular LVH44 into rigid wall opening (note: air transfer grille does not have to be centrally positioned in the opening).
- ▶ Fix the angles to the masonry wall with masonry anchors.
- ▶ Apply a bead of Lorient intumescent sealant to full depth around the perimeter of LVH44 as shown (note: maximum clearance of 25mm applies).
- ▶ Connect ductwork (or cover grille) directly to wall using approved breakaway connections to ensure compliance.
- ▶ **Note: Fixings supplied by others.**

# WALL 9

## LVH44 MODULAR SYSTEM FITTED INTO RIGID WALL WITH Z SECTION FIXINGS

### DESCRIPTION

- 1 Rigid wall
- 2 Lorient LVH44 intumescent air transfer grille
- 3 Lorient intumescent sealant around LVH44 perimeter to a maximum clearance of 25mm
- 4 **Fixing angle:** Full width galvanised steel Z sections (40 x 20 x 1mm thick minimum) around perimeter of LVH44 on both sides with 200mm fixing centres
- 5 Air transfer grilles slot together using tab system

**Note:** For modular systems a 10mm (min) clearance around perimeter is needed

### CONTENTS

- LVH44 air transfer grille
- Cover grille (optional)

### TOOLS REQUIRED

- Z section
- Masonry anchors
- Self tapping screws (3.5 x 16mm)
- Lorient intumescent sealant

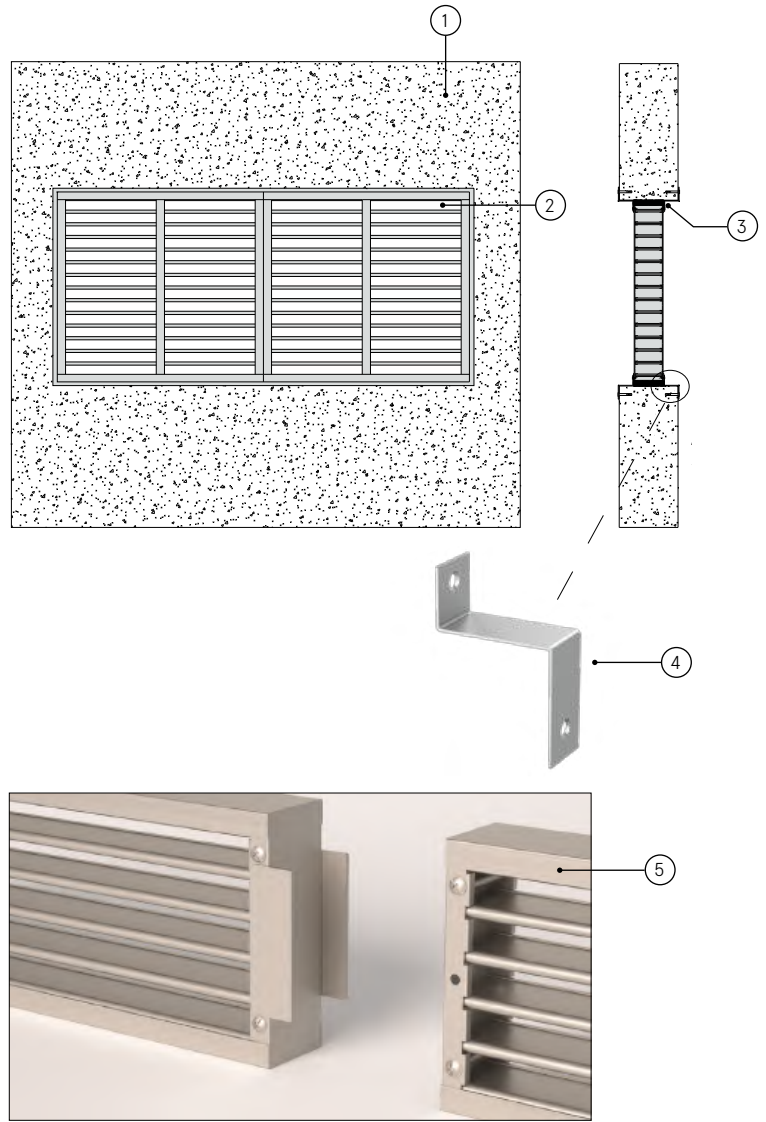

### LVH44 modular systems for rigid wall with Z section fixings

#### FR120

#### Fire Resistance in accordance with

BS 476-22:1987

#### Approval Ref

WFRC 121316 (AW9)

#### Max size.

1200mm x 600mm

Larger sizes can be used with a different mounting detail.

LVH44 air transfer grilles are supplied 2mm less than the nominal size e.g. a 300mm x 300mm is actually 298mm x 298mm.

### INSTALLATION INSTRUCTIONS

- ▶ Slide the LVH44 modules together ensuring a bead of Lorient intumescent sealant is used in between LVH44 modules.
- ▶ Secure tab with self tapping screws into LVH44.
- ▶ Fix the mounting Z sections onto the LVH44 using self tapping screws to **both sides of the modular air transfer grille.**
- ▶ Insert LVH44 into rigid wall opening (note: air transfer grille does not have to be centrally positioned in the opening).
- ▶ Fix the Z sections to the rigid wall with masonry anchors.
- ▶ Apply a bead of Lorient intumescent sealant to full depth around the perimeter of air transfer grille as shown (note: maximum clearance of 25mm applies).
- ▶ Connect ductwork (or cover grille) directly to wall using approved breakaway connections to ensure compliance.
- ▶ **Note: Fixings supplied by others.**



# WALL 11

## LVH44 FITTED INTO RIGID WALL CONSTRUCTION

### DESCRIPTION

- 1 Rigid wall construction
- 2 Mortar facing over irregular surface
- 3 Aluminium cover grille
- 4 LVH44 air transfer grille
- 5 Air transfer grille fixing screws into wall plugs
- 6 Use Lorient intumescent sealant to bed air transfer grille into the wall
- 7 Cover grille fixing screws into wall plugs.

### CONTENTS

- LVH44 air transfer grille
- Aluminium cover grille (optional)

### TOOLS REQUIRED

- 50mm screws
- Wall plugs for 50mm screws
- Lorient intumescent sealant

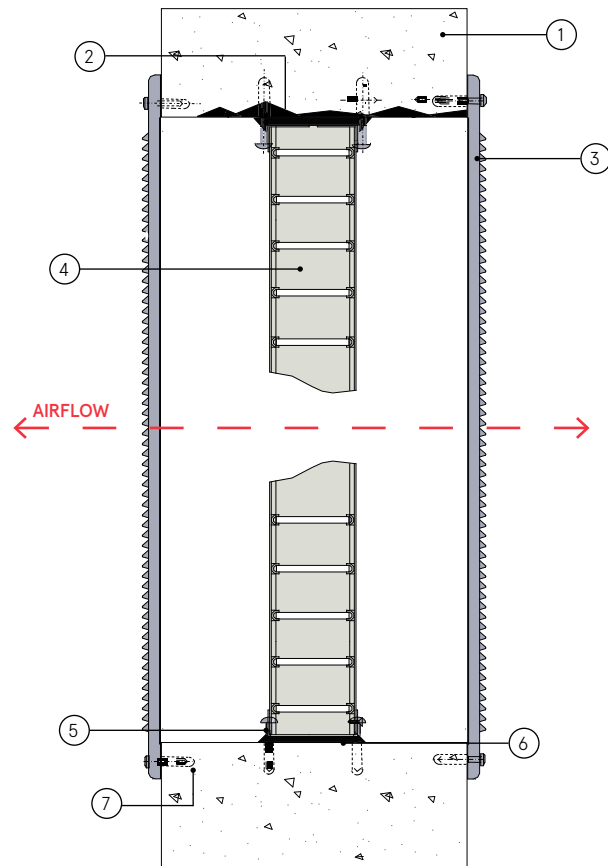

**Note:** To achieve insulating rating, an aluminium cover grille must be fitted.

### LVH44 fitted into rigid walls

#### EI90\*/EI120\*\*

#### Fire Resistance in accordance with

BS EN 1364-5:2017

#### Approval Ref

19/19894-253

#### Max single cell size

\*1000mm (w) x 500mm (h)

\*\* 600mm x 600mm

LVH44 air transfer grilles are supplied 2mm less than the nominal size e.g. a 300mm x 300mm is actually 298mm x 298mm.

### INSTALLATION INSTRUCTIONS

- ▶ Cut the aperture to the required size with a maximum gap all around of 5mm. If resulting aperture is out of square, irregular or oversized, make good with mortar.
- ▶ Trial fit the LVH44 into the aperture and ensure that it can be positioned within the section of the wall but not necessarily in the mid position, without jamming or twisting.
- ▶ Mark the position of drill points into wall either side of the LVH44.
- ▶ Remove the LVH44 from the wall aperture.
- ▶ Fix screws into wall with a minimum of 4 screws around the perimeter. For larger units use a maximum of 200mm between centres to provide up to 8 screws per side.
- ▶ Position LVH44 and repeat installation of screws on closest side of the LVH44.
- ▶ Bed in sealant around LVH44. Clean off surplus and ensure outer edge of the air transfer grille is fully sealed.
- ▶ Position aluminium cover grille centrally over one face of the LVH44 and fix using wall plugs supplied.
- ▶ Repeat to other face if two cover grilles are to be fitted.
- ▶ **Note: Fixings supplied by others.**

# WALL 12

## LVV40 FITTED INTO RIGID WALL CONSTRUCTION

### DESCRIPTION

1	Rigid wall construction
2	Mortar facing over irregular surface
3	Pressed steel or aluminium cover grille
4	LVV40 air transfer grille
5	Air transfer grille fixing screws into wall plugs
6	Use Lorient intumescent sealant to bed air transfer grille into the wall
7	Cover grille fixing screws into wall plugs.

In order to comply with CF564, the upper edge of the grille shall be no higher than 3000mm from floor level. The lower edge of the grille shall be no closer than 400mm to floor level.

### CONTENTS

- LVV40 air transfer grille
- Cover grille (optional)

### TOOLS REQUIRED

- 50mm screws
- Wall plugs for 50mm screws
- Lorient intumescent sealant

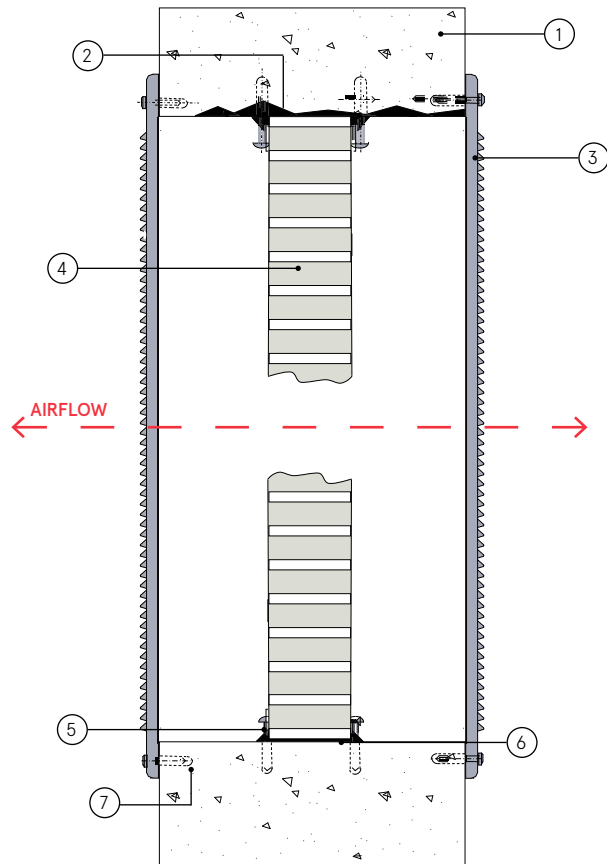

### LVV40 into a rigid wall

## FR60

### Fire Resistance in accordance with

BS 476-22:1987

### Approval Ref

WF185829/A  
Certifire CF564

### Max single cell size

600mm x 600mm

LVV40 air transfer grilles are supplied 2mm less than the nominal size e.g. a 300mm x 300mm is actually 298mm x 298mm.

### INSTALLATION INSTRUCTIONS

- ▶ Cut the aperture to the required size with a maximum gap all around of 5mm. If resulting aperture is out of square, irregular or oversized, make good with mortar.
- ▶ Trial fit the LVV40 into the aperture and ensure that it can be positioned within the section of the wall but not necessarily in the mid position, without jamming or twisting.
- ▶ Mark the position of drill points into wall either side of the LVV40.
- ▶ Remove the LVV40 from the wall aperture.
- ▶ Fix screws through side wall of LVV40 with a minimum of 4 screws. For larger units use a maximum of 200mm between centres.
- ▶ Position LVV40 and repeat installation of screws on closest side of the LVV40.
- ▶ Bed in sealant around LVV40. Clean off surplus and ensure outer edge of the air transfer grille is fully sealed.
- ▶ Position cover grille centrally over one face of the LVV40 and fix using wall plugs supplied.
- ▶ Repeat to other face if two cover grilles are to be fitted.
- ▶ **Note: Fixings supplied by others.**

# WALL 13

## LVC40 FITTED INTO RIGID WALL CONSTRUCTION

### DESCRIPTION

- 1 Rigid wall construction
- 2 Mortar facing over irregular surface
- 3 Pressed steel or aluminium cover grille
- 4 LVC40 air transfer grille
- 5 Air transfer grille fixing screws into wall plugs
- 6 Use Lorient intumescent sealant to bed air transfer grille into the wall
- 7 Cover grille fixing screws into wall plugs.

In order to comply with CF564, the upper edge of the grille shall be no higher than 3000mm from floor level. The lower edge of the grille shall be no closer than 400mm to floor level.

### CONTENTS

- LVC40 air transfer grille
- Cover grille (optional)

### TOOLS REQUIRED

- 4 x 50mm screws
- Wall plugs for 4 x 50mm screws
- Lorient intumescent sealant

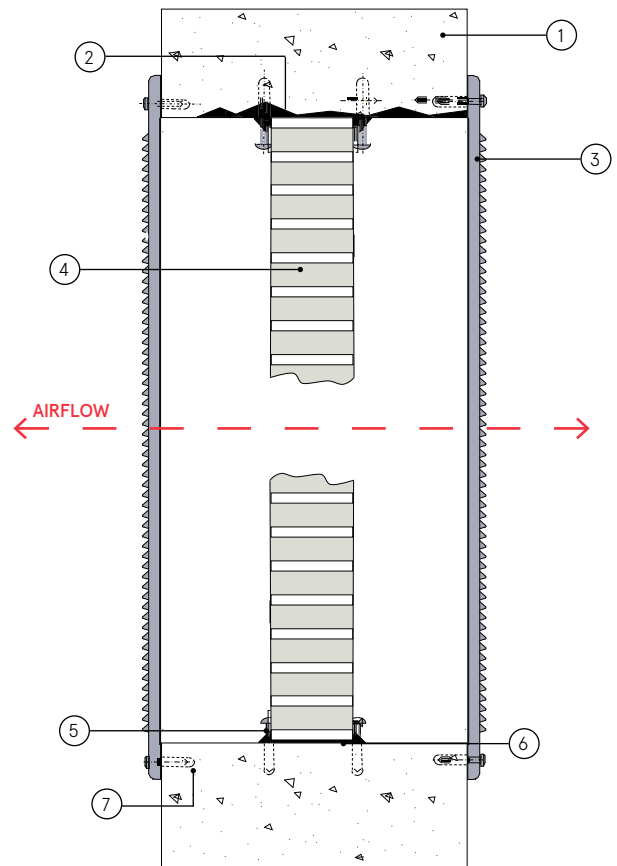
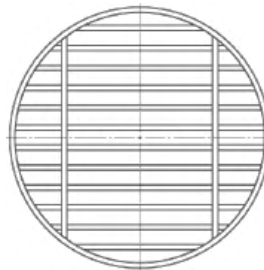

### LVC40 into a rigid wall

## FR60

### Fire Resistance in accordance with

BS 476-22:1987

### Approval Ref

WF185829/A  
Certifire CF564

### Max single cell size

600mm x 600mm

LVC40 air transfer grilles are supplied 2mm less than the nominal size e.g. a 300mm x 300mm is actually 298mm x 298mm.

### INSTALLATION INSTRUCTIONS

- ▶ Cut the aperture to the required size with a maximum gap all around of 5mm. If resulting aperture is out of square, irregular or oversized, make good with mortar.
- ▶ Trial fit the LVC40 into the aperture and ensure that it can be positioned within the section of the wall but not necessarily in the mid position, without jamming or twisting.
- ▶ Mark the position of drill points into wall either side of the LVC40.
- ▶ Remove the LVC40 from the wall aperture.
- ▶ Fix screws into wall with a minimum of 4 screws along the perimeter.
- ▶ Position LVC40 and repeat installation of screws on closest side of the LVC40.
- ▶ Bed in sealant around LVC40. Clean off surplus and ensure outer edge of the air transfer grille is fully sealed.
- ▶ Position cover grille centrally over one face of the LVC40 and fix using wall plugs supplied.
- ▶ Repeat to other face if two cover grilles are to be fitted.
- ▶ **Note: Fixings supplied by others.**

# WALL 14

## LVV40 FITTED INTO RIGID WALL CONSTRUCTION

### DESCRIPTION

- 1 Rigid wall construction
- 2 Mortar facing over irregular surface
- 3 Pressed steel cover grille
- 4 LVV40 air transfer grille
- 5 Air transfer grille fixing screws into wall plugs
- 6 Use Lorient intumescent sealant to bed air transfer grille into the wall
- 7 Cover grille fixing screws into wall plugs.

### CONTENTS

- LVV40 air transfer grille
- Pressed steel cover grille

### TOOLS REQUIRED

- 50mm screws
- Wall plugs for 50mm screws
- Lorient intumescent sealant

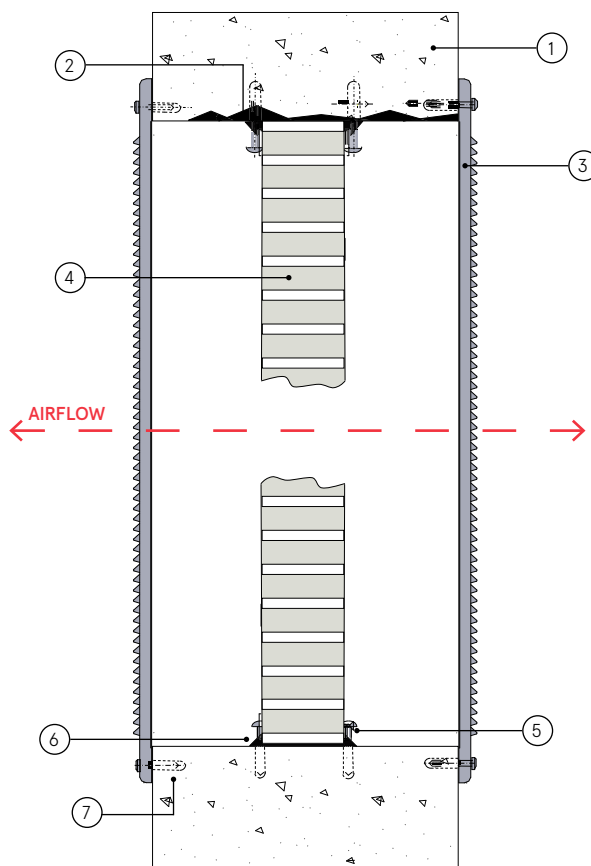

**Note:** To achieve insulating rating, a cover grille must be fitted.

### LVV40 fitted into rigid wall construction

## E1120

**Fire Resistance in accordance with**  
BS EN 1364-5:2017

**Approval Ref**  
19/19894-253

**Max single cell size**  
600mm x 600mm

LVV40 air transfer grilles are supplied 2mm less than the nominal size e.g. a 300mm x 300mm is actually 298mm x 298mm.

### INSTALLATION INSTRUCTIONS

- ▶ Cut the aperture to the required size with a maximum gap all around of 5mm. If resulting aperture is out of square, irregular or oversized, make good with mortar.
- ▶ Trial fit the LVV40 into the aperture and ensure that it can be positioned within the section of the wall, but not necessarily in the mid position, without jamming or twisting.
- ▶ Mark the position of drill points into wall either side of the LVV40.
- ▶ Remove the LVV40 from the wall aperture.
- ▶ Fix screws into wall with a minimum of 4 screws along the perimeter. For larger units use a maximum of 200mm between centres to provide up to 8 screws per side.
- ▶ Position LVV40 and repeat installation of screws on closest side of the LVV40.
- ▶ Bed in sealant around LVV40. Clean off surplus and ensure outer edge of the air transfer grille is fully sealed.
- ▶ Position pressed steel cover grille centrally over one face of the LVV40 and fix using wall plugs supplied.
- ▶ Repeat to other face if two cover grilles are to be fitted.
- ▶ **Note: Fixings supplied by others.**

# WALL 15

## LVV40 FITTED INTO FIRE RATED FLEXIBLE WALLS

### DESCRIPTION

1	Fire rated flexible wall (Group B/C)
2	Aperture lining
3	Air transfer grille fixing screws
4	Use intumescent sealant to bed LVV40 into wall
5	Pressed steel cover grille
6	LVV40 air transfer grille
7	Cover grille fixing screws into wall.

### CONTENTS

- LVV40 air transfer grille
- Pressed steel cover grille

### TOOLS REQUIRED

- Drywall screws (3.5 x 42mm)
- Lorient intumescent sealant

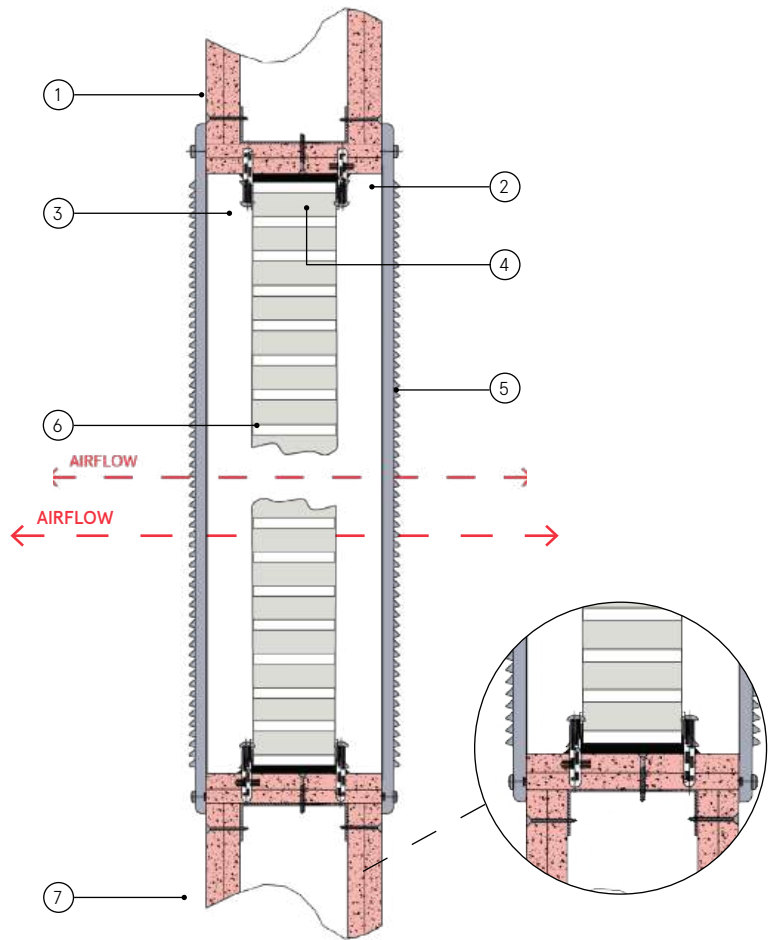

**Note:** To achieve insulating rating, a cover grille must be fitted.

### LVV40 fitted into FR flexible wall

## EI60

### Fire Resistance in accordance with

BS EN 1364-5:2017

### Approval Ref

LBO-1333/19E

### Max single cell size

600mm x 600mm

LVV40 air transfer grilles are supplied 2mm less than the nominal size e.g. a 300mm x 300mm is actually 298mm x 298mm.

### INSTALLATION INSTRUCTIONS

- ▶ Cut the aperture to the required size with a maximum gap all around of 5mm. Frame in aperture faces. Ensure the final aperture is square and to correct size.
- ▶ Trial fit the LVV40 into the aperture and ensure that it can be positioned within the section of the wall, but not necessarily in the mid position, without jamming or twisting.
- ▶ Mark the position of drill points into wall either side of the LVV40.
- ▶ Remove the LVV40 from the wall aperture.
- ▶ Fix screws into wall with a minimum of 4 screws along the perimeter. For larger units use a minimum of 200mm between centres to provide up to 8 screws per side.
- ▶ Position LVV40 and repeat installation of screws on closest side of the LVV40.
- ▶ Bed in sealant around LVV40. Clean off surplus and ensure outer edge of the air transfer grille is fully sealed.
- ▶ Position pressed steel cover grille centrally over one face of the LVV40 and fix using drywall screws.
- ▶ Repeat to other face if two cover grilles are to be fitted.
- ▶ **Note: Fixings supplied by others.**

# WALL 16

## LVV40S FIRE + SMOKE AIR TRANSFER GRILLE FITTED INTO RIGID WALLS

### DESCRIPTION

1	Rigid wall
2	Air transfer grille casing fixing screw
3	Mortar facing over irregular surface
4	Mineral board casing
5	Pressed steel cover grille
6	LVV40S fire + smoke air transfer grill
7	Actuator cable
8	Servo driven actuator
9	Intumescent sealant to bed casing into wall
10	Cover grille fixing screws into wall plugs

**Note:** In order to comply with CF564, the upper edge of the grille shall be no higher than 3000mm from floor level. The lower edge of the grille shall be no closer than 400mm to floor level.

### CONTENTS

- LVV40S fire + smoke resistant air transfer grille
- Cover grille (optional)
- Wiring instructions

### TOOLS REQUIRED

- 50mm screws
- Wall plugs for 50mm screws
- Cable clips
- Lorient intumescent sealant

**Note:** To achieve insulating rating, a cover grille must be fitted.

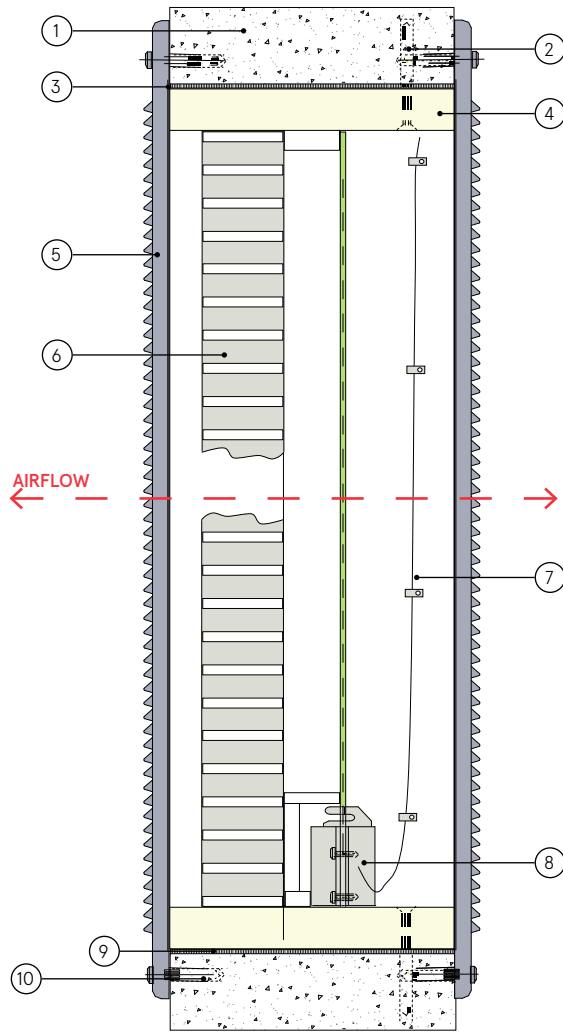

### LVV40S fitted into rigid walls

#### EI60S/FR90S\*

#### Fire Resistance in accordance with

BS 476-22:1987  
BS EN 1364-5:2017

#### Approval Ref

\*Certifire CF564  
18/17274-1071

#### Max single cell size

600mm (w) x 400mm (h)  
(640mm x 440mm overall)  
or 0.2025m<sup>2</sup> - Certifire

LVV40S comes in a non-combustible housing which means the actual size of the product is approx. 40mm larger. E.g. a 300mm x 300mm damper is actually 340mm x 340mm due to the housing.

### INSTALLATION INSTRUCTIONS

- ▶ LVV40S dampers are supplied ready assembled in a mineral board casing. Care must be taken not to damage the casing during installation.
- ▶ Cut the aperture to the required size with a maximum gap all around of 5mm. If the resulting aperture is out of square, irregular or oversized, make good with mortar.
- ▶ If the LVV40S is already fitted with cover grilles these must be removed.
- ▶ Drill the casing for fixing screws to the wall, minimum of 4 number will be needed.
- ▶ Trial fit the LVV40S assembly into the aperture and ensure that it can be positioned within the section of the wall, without jamming or twisting.
- ▶ Position the LVV40S assembly so that one face is flush with one face of the wall. Mark around the air transfer grille (ATG) casing at the opposite face to determine the amount needed to be removed to give a flush fit on both faces. Also mark the positions of the wall fixing screws through the holes drilled.
- ▶ Establish the actuator cable run and make the necessary cut outs to suit.
- ▶ Remove the ATG assembly from the wall aperture. Trim the ATG casing to the marked length.
- ▶ Drill the wall for screw plugs and fit plugs.
- ▶ Apply Lorient intumescent sealant to aperture faces. Position ATG assembly square and flush to both faces of the wall while feeding the actuator cable into the selected position.
- ▶ Bed in sealant around LVV40S casing. Clean off surplus sealant and ensure outer edge of LVV40S casing is fully sealed.
- ▶ Fix actuator cable to casing with small cable clips to prevent it fouling the shutter plates.
- ▶ See wiring instructions.
- ▶ Carry out function check of the ATG by activation from the control unit.
- ▶ After satisfactorily completing the function test, position a pressed steel cover grille concentrically over one face of the LVV40S and fix using screws into wall plugs.
- ▶ Repeat to other face if two cover grilles are to be fitted.

# WALL 17

## LVV40S FIRE + SMOKE AIR TRANSFER GRILLE FITTED INTO FIRE RATED FLEXIBLE WALLS

### DESCRIPTION

1	Fire rated flexible wall (Group B/C)
2	Air transfer grille casing fixing screw
3	Mineral board casing
4	Pressed steel cover grille
5	LVV40S fire + smoke air transfer grille
6	Actuator cable
7	Servo driven actuator
8	Intumescent sealant to bed casing into wall
9	Cover grille fixing screws.

### CONTENTS

- LVV40S fire + smoke resistant air transfer grille
- Pressed steel cover grille
- Wiring instructions

### TOOLS REQUIRED

- Cable clips
- Screws (3.5 x 42mm)
- Lorient intumescent sealant

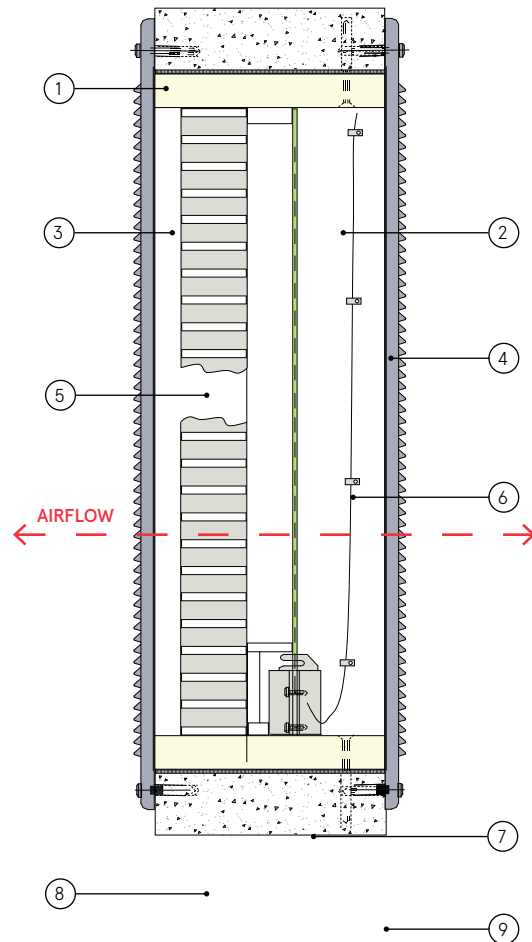

**Note:** To achieve insulating rating, a cover grille must be fitted.

### LVV40S fitted into FR flexible walls

## EI60S

### Fire Resistance in accordance with

BS EN 1364-5:2017

### Approval Ref

LBO-1333/19E

### Max single cell size

600mm (w) x 400mm (h)  
(640mm x 440mm overall)

LVV40S comes in a non-combustible housing which means the actual size of the product is approx. 40mm larger. E.g. a 300mm x 300mm damper is actually 340mm x 340mm due to the housing.

### INSTALLATION INSTRUCTIONS

- ▶ LVV40S dampers are supplied ready assembled in a mineral board casing. Care must be taken not to damage the casing during installation.
- ▶ Cut the aperture to the required size with a maximum gap all around of 5mm. Frame in aperture faces. Ensure final aperture is square and correct to size.
- ▶ If the LVV40S is already fitted with cover grilles these must be removed.
- ▶ Drill the casing for fixing screws to the wall, minimum of 4 number will be needed.
- ▶ Trial fit the air transfer grille (ATG) assembly into the aperture and ensure that it can be positioned within the section of the wall, without jamming or twisting.
- ▶ Position the LVV40S assembly so that one face is flush with one face of the wall. Mark around the ATG casing at the opposite face to determine the amount needed to be removed to give a flush fit on both faces. Also mark the positions of the wall fixing screws through the holes drilled.
- ▶ Establish the actuator cable run and make the necessary cut outs to suit.
- ▶ Remove the LVV40S assembly from the wall aperture. Trim the ATG casing to the marked length.
- ▶ Apply intumescent sealant to aperture faces. Position LVV40S assembly square and flush to both faces of the wall while feeding the actuator cable into the selected position.
- ▶ Fit casing fixing screws to wall.
- ▶ Bed in sealant around ATG casing. Clean off surplus sealant and ensure outer edge of LVV40S casing is fully sealed.
- ▶ Fix actuator cable to casing with small cable clips to prevent it fouling the shutter plates.
- ▶ See wiring instructions.
- ▶ Carry out function check of the damper by activation from the control unit.
- ▶ After satisfactorily completing the function test, position a pressed steel cover grille concentrically over one face of the LVV40S and fix using screws.
- ▶ Repeat to other face if two cover grilles are to be fitted.



# WALL 18

## LVH44S FIRE + SMOKE AIR TRANSFER GRILLE FITTED INTO RIGID WALLS

**DESCRIPTION**

- 1 Rigid wall construction
- 2 Mineral board casing
- 3 Air transfer grille casing fixing screw
- 4 LVH44S fire + smoke air transfer grille
- 5 Pressed steel cover grille
- 6 Actuator cable
- 7 Servo driven actuator
- 8 Intumescent sealant to bed casing into wall
- 9 Cover grille fixing screws into wall plugs.

**CONTENTS**

- LVH44S fire + smoke resistant air transfer grille
- Cover grille (optional)
- Wiring instructions

**TOOLS REQUIRED**

- 50mm screws
- Wall plugs for 50mm screws
- Lorient intumescent sealant

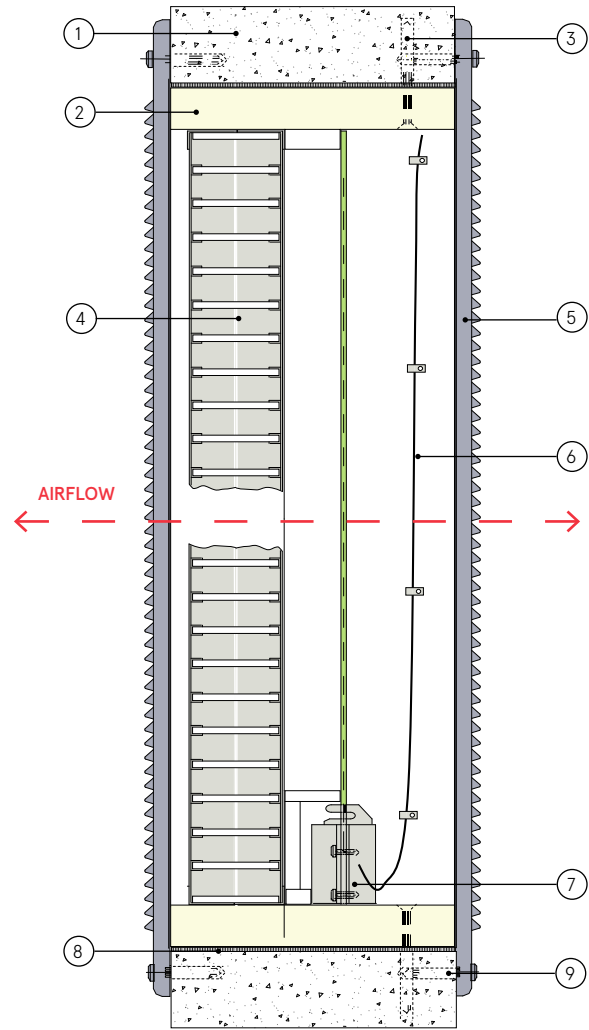

### LVH44S fitted into rigid wall construction

### FR120S

**Fire Resistance in accordance with**

BS 476-22:1987

**Approval Ref**

WFRC C121316

**Max single cell size**

600mm x 600mm  
(640mm x 640mm overall)

LVH44S comes in a non-combustible housing which means the actual size of the product is approx. 40mm larger. E.g. a 300mm x 300mm LVH44S is actually 340mm x 340mm due to the housing.

**INSTALLATION INSTRUCTIONS**

- ▶ **LVH44S air transfer grilles are supplied ready assembled in a mineral board casing. Care must be taken not to damage the casing during installation.**
- ▶ Cut the aperture to the required size with a maximum gap all around of 5mm. If the resulting aperture is out of square, irregular or oversized, make good with mortar.
- ▶ If the LVH44S is already fitted with cover grilles these must be removed.
- ▶ Drill the casing for fixing screws to the wall, minimum of 4 number will be needed.
- ▶ Trial fit the LVH44S assembly into the aperture and ensure that it can be positioned within the section of the wall, without jamming or twisting.
- ▶ Position the LVH44S assembly so that one face is flush with one face of the wall. Mark around the casing at the opposite face to determine the amount needed to be removed to give a flush fit on both faces. Also mark the positions of the wall fixing screws through the holes drilled.
- ▶ Establish the actuator cable run and make the necessary cut outs to suit.
- ▶ Remove the LVH44S assembly from the wall aperture. Trim the damper casing to the marked length.
- ▶ Drill the wall for screw plugs and fit plugs.
- ▶ Apply intumescent sealant to aperture faces. Position the LVH44S square and flush to both faces of the wall while feeding the actuator cable into the selected position.
- ▶ Bed in sealant around LVH44S casing. Clean off surplus sealant and ensure outer edge of LVH44S casing is fully sealed.
- ▶ Fix actuator cable to casing with small cable clips to prevent it fouling the shutter plates.
- ▶ See wiring instructions.
- ▶ Carry out function check of the LVH44S by activation from the control unit.
- ▶ After satisfactorily completing the function test, position a pressed steel cover grille concentrically over one face of the LVH44S and fix using screws into wall plugs.
- ▶ Repeat to other face if two cover grilles are to be fitted.

# WALL 19

## LVH44S FIRE + SMOKE AIR TRANSFER GRILLE FITTED INTO FIRE RATED FLEXIBLE WALLS

### DESCRIPTION

1	FR Flexible wall
2	Air transfer grille casing fixing screw
3	Mineral board facing
4	Pressed steel cover grille
5	LVH44S fire + smoke air transfer grille
6	Actuator cable
7	Servo driven actuator
8	Intumescent sealant to bed casing into wall
9	Cover grille fixing screws into wall plugs.

### CONTENTS

- LVH44S fire + smoke resistant air transfer grille
- Cover grille (optional)
- Wiring instructions

### TOOLS REQUIRED

- Cable clips
- Screws (3.5 x 42mm)
- Lorient intumescent sealant

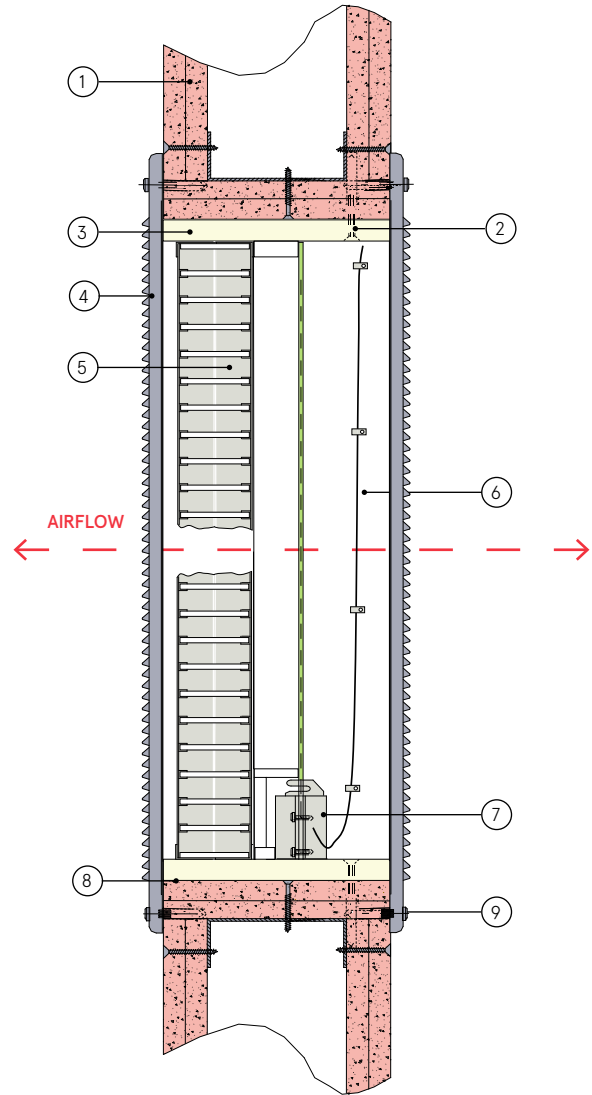

### LVH44S fitted into fire rated flexible wall

## FR120S

### Fire Resistance in accordance with

BS 476-22:1987

### Approval Ref

WFRC C121316

### Max single cell size

600mm x 600mm  
(640mm x 640mm overall)



















LVH44S comes in a non-combustible housing which means the actual size of the product is approx. 40mm larger. E.g. a 300mm x 300mm damper is actually 340mm x 340mm due to the housing.

### INSTALLATION INSTRUCTIONS

- ▶ LVH44S fire + smoke resistant air transfer grilles are supplied ready assembled in a mineral board casing. Care must be taken not to damage the casing during installation.
- ▶ Cut the aperture to the required size with a maximum gap all around of 5mm. Frame in aperture faces. Ensure final aperture is square and correct to size.
- ▶ If the LVH44S is already fitted with cover grilles these must be removed.
- ▶ Drill the casing for fixing screws to the wall, minimum of 4 number will be needed.
- ▶ Trial fit the LVH44S assembly into the aperture and ensure that it can be positioned within the section of the wall, without jamming or twisting.
- ▶ Position the LVH44S assembly so that one face is flush with one face of the wall. Mark around the LVH44S casing at the opposite face to determine the amount needed to be removed to give a flush fit on both faces. Also mark the positions of the wall fixing screws through the holes drilled.
- ▶ Establish the actuator cable run and make the necessary cut outs to suit.
- ▶ Remove the LVH44S assembly from the wall aperture. Trim the air transfer grille casing to the marked length.
- ▶ Apply intumescent sealant to aperture faces. Position LVH44S assembly square and flush to both faces of the wall while feeding the actuator cable into the selected position.
- ▶ Fit casing fixing screws to wall.
- ▶ Bed intumescent sealant around the LVH44S casing. Clean off surplus sealant and ensure outer edge of LVH44S casing is fully sealed.
- ▶ Fix actuator cable to casing with small cable clips to prevent it fouling the shutter plates.
- ▶ See wiring instructions.
- ▶ Carry out function check of the LVH44S by activation from the control unit.
- ▶ After satisfactorily completing the function test, position a pressed steel cover grille concentrically over one face of the LVH44S and fix using screws into wall plugs.
- ▶ Repeat to other face if two cover grilles are to be fitted.

# DUCT MOUNTED SYSTEMS

Fitted into ducts, our intumescent air transfer grilles and fire dampers combine air movement with fire protection. They provide a cost effective solution in allowing free air movement and yet maintain the integrity of the duct in a fire situation.

System	 	Fire Rating	Application	Product	Page No.
Duct 1		FR60	Circular plastic duct	LVC40	51
Duct 2		EI60/EI120	Circular galvanised steel duct	LVC40	52
Duct 3		FR120	Rectangular steel duct	LVH44	53
Duct 4		FR120	Insulated duct section	LVH44	54
Duct 5		FR120	Rigid wall construction with angle fixings to wall (Duct to Duct)	LVHC44	55
Duct 6		FR120	Rigid wall construction with angle clamps (Duct to Duct)	LVHC44	56
Duct 7		FR120	Fire rated flexible wall with angle fixings to wall	LVHC44	57
Duct 8		FR120	Fire rated flexible wall with angle clamps	LVHC44	58
Duct 9		FR120	Rigid wall construction with angle fixings (Duct to Grille)	LVHC44	59
Duct 10		FR120	Rigid wall construction (Duct to Duct)	LVH44	60
Duct 11		FR120	Fire rated flexible wall (Duct to Duct)	LVH44	61
Duct 12		FR120	Fire rated flexible wall (Duct to Grille)	LVH44	62
Duct 13		FR120	Rigid wall construction with metal casing (Duct to Grille)	LVH44	63
Duct 14		E240/EI30	Rectangular steel duct	LVH54	64
Duct 15	 	FR120/FR240	Rectangular steel duct	LVHCTD + LVH44/LVH54	65
B1			Angle flange connection directly to wall		66
B2			Channel connection directly to wall		66
B3			TDF flange connection directly to wall		67

# DUCT 1

## LVC40 CIRCULAR AIR TRANSFER GRILLE INSTALLATION IN PLASTIC PIPE

### DESCRIPTION

- 1 Rigid wall construction
- 2 Mineral wool or mortar packing
- 3 Intumescent sealant
- 4 Plastic pipe
- 5 LVC40 air transfer grille
- 6 Self tapping screws.

### CONTENTS

- LVC40 air transfer grille

### TOOLS REQUIRED

- Lorient intumescent sealant
- Self tapping screws (3.2mm x 16mm or longer as required)
- Mineral wool or mortar

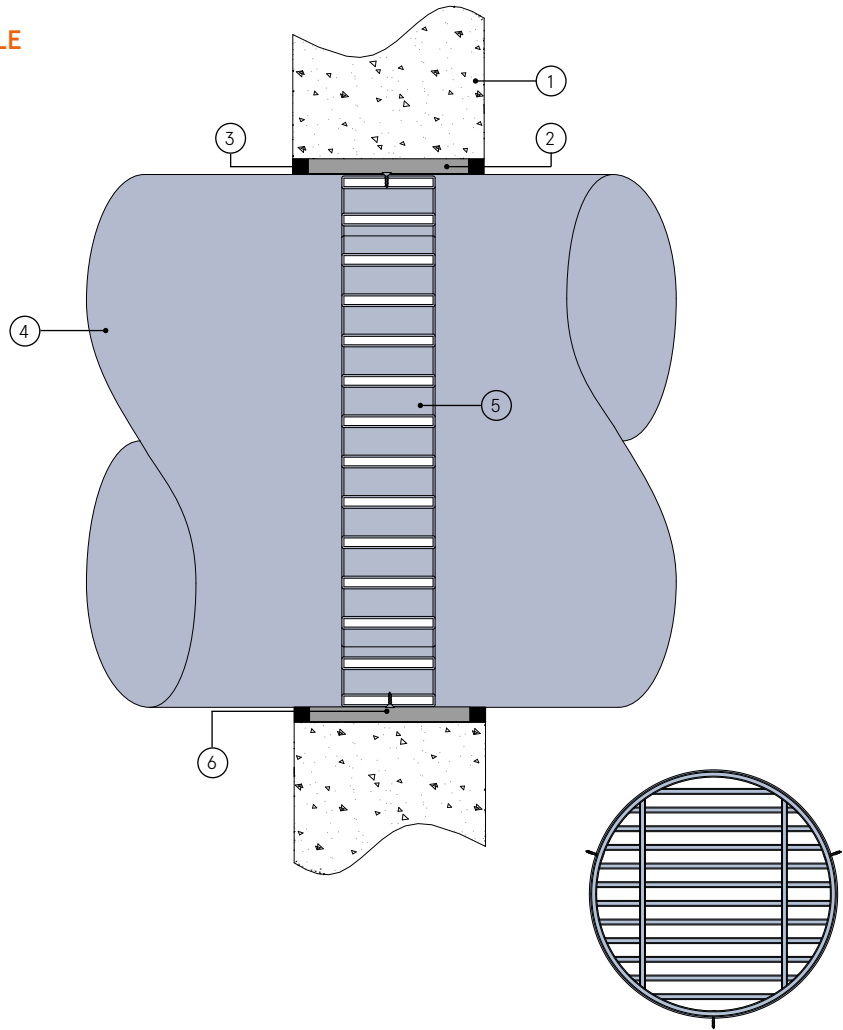

**Note:** LVC40 air transfer grilles are supplied 2mm less than the nominal size e.g. a 150mm is actually 148mm.

### LVC40 circular air transfer grille installation in plastic pipes

#### FR60

#### Fire Resistance in accordance with

BS 476-20:1987

#### Approval Ref

WF185829/A

#### Max single cell size

150mm diameter

LVC40 air transfer grilles are supplied 2mm less than the nominal size e.g. a 150mm is actually 148mm.

### INSTALLATION INSTRUCTIONS

- ▶ Cut aperture in wall a least 30mm larger than the outside diameter of the pipe.
- ▶ Pass pipe through aperture into correct linear location and mark positions of both wall faces on pipe.
- ▶ Remove pipe from aperture and position LVC40 in pipe midway between the two wall marks.
- ▶ Drill through pipe wall into LVC40 outer frame and fit at least 3 number self tapping screws to retain air transfer grille.
- ▶ Seal joints between edges of LVC40 and pipe wall with intumescent sealant.
- ▶ Position pipe and LVC40 assembly into aperture and accurately align with other pipe sections, whilst packing aperture with mineral wool or mortar.
- ▶ Seal over packing material with intumescent sealant.

# DUCT 2

## LVC40 INSTALLATION IN CIRCULAR GALVANISED STEEL DUCTS

### DESCRIPTION

- |   |   |
|---|---|
| 1 | Rigid wall construction   |
| 2 | Mineral wool packing  |
| 3 | Intumescent sealant seal  |
| 4 | Joining collar  |
| 5 | Joining collar galvanised   |
| 6 | LVC40 air transfer grille   |
| 7 | Bed in intumescent sealant  |
| 8 | Fixing angle: 100 x 100 x 1.2mm thick minimum galvanised steel angles fixed to air transfer grille unit with self tapping screws and to wall with masonry anchors |
| 9 | Masonry anchors   |

### CONTENTS

- LVC40 air transfer grille

### TOOLS REQUIRED

- 3.2 x 16mm self tapping screws / Nut + Bolt
- Fixing angles
- Masonry anchors
- Mineral wool
- Wall fixings
- Internal joining collar
- Lorient intumescent sealant

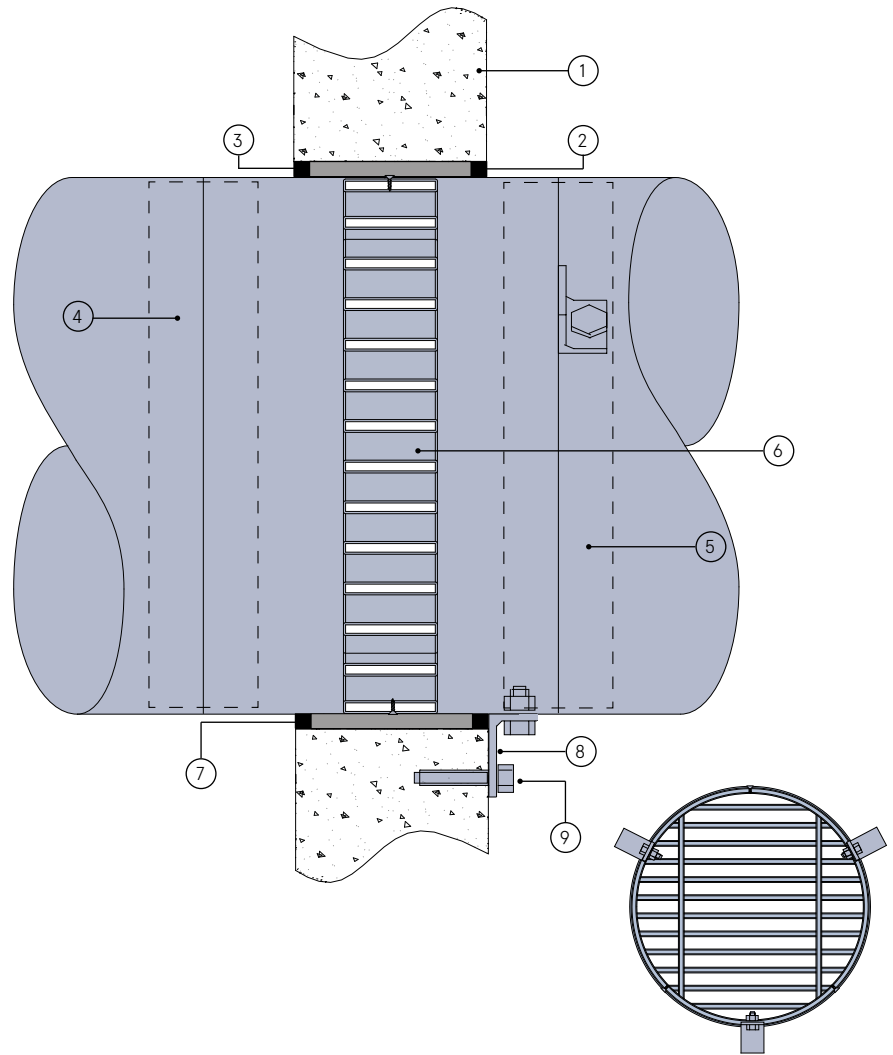

### LVC40 installation into galvanised steel ducts

#### FR60

#### Fire Resistance in accordance with

BS 476-20:1987

#### Approval Ref

WF185829/A

#### Max single cell size

600mm diameter

LVC40 air transfer grilles are supplied 2mm less than the nominal size e.g. a 150mm is actually 148mm.

### INSTALLATION INSTRUCTIONS

- ▶ Prepare a short piece of duct at least 150 mm longer than the thickness of wall to be penetrated (100mm wall thickness will require a minimum duct length of 250mm).
- ▶ Position the intumescent air transfer grille into the duct at point where it will be approximately on the centre line of the wall thickness when the duct is fitted into a wall aperture.
- ▶ Fix air transfer grille into position in duct using 16mm self tapping screws.
- ▶ Seal periphery between duct inner face and air transfer grille frame with intumescent sealant.
- ▶ Cut aperture in wall at least 10mm greater than the outside diameter of the duct section.
- ▶ Place duct and air transfer grille assembly into aperture ensuring air transfer grille is positioned inside the wall section.
- ▶ Mark on the duct the position of a least 3 number wall fixing angles.
- ▶ Remove duct from wall aperture and fit fixing angles to duct using nuts and bolts. (Note: the vertical angle that face to the wall must overlap the aperture by at least 25mm to provide good anchorage for wall fixings)
- ▶ Position duct assembly into wall and pack around with mineral wool keeping the duct assembly central to the aperture and in alignment with the wall face.
- ▶ Fix in position with fasteners through mounting angles into wall.
- ▶ Seal over the mineral wool packing with intumescent sealant.
- ▶ Fit an internal joining collar into each end of the duct + air transfer grille assembly.
- ▶ Secure using self tapping screws and seal with intumescent sealant.
- ▶ Connect the duct + air transfer grille assembly to main duct sections.

# DUCT 3

## LVH44 INSTALLATION FOR RECTANGULAR STEEL DUCTS

DESCRIPTION	
1	Wall
2	50mm wall anchors
3	Mouting angle 75 x 25 x 1.2mm galvanised steel
4	Damper retaining bracket 20 x 20 x 1mm galvanised steel fixed with short self tapping screws
5	Galvanised steel duct
6	LVH44 intumescent air transfer grille
7	Peripheral intumescent sealant bead
8	Minimum of 15mm wool
9	Joining angle 25 x 25 x 1.2mm galvanised steel.

### CONTENTS

- LVH44 air transfer grille

### TOOLS REQUIRED

- 50mm wall anchors
- Mouting angle (75 x 25 x 1.2mm galvanised steel)
- Retaining bracket 1mm (25mm x 25mm)
- Short self tapping screws (3.2mm x 16mm)
- Mineral wool
- Lorient intumescent sealant

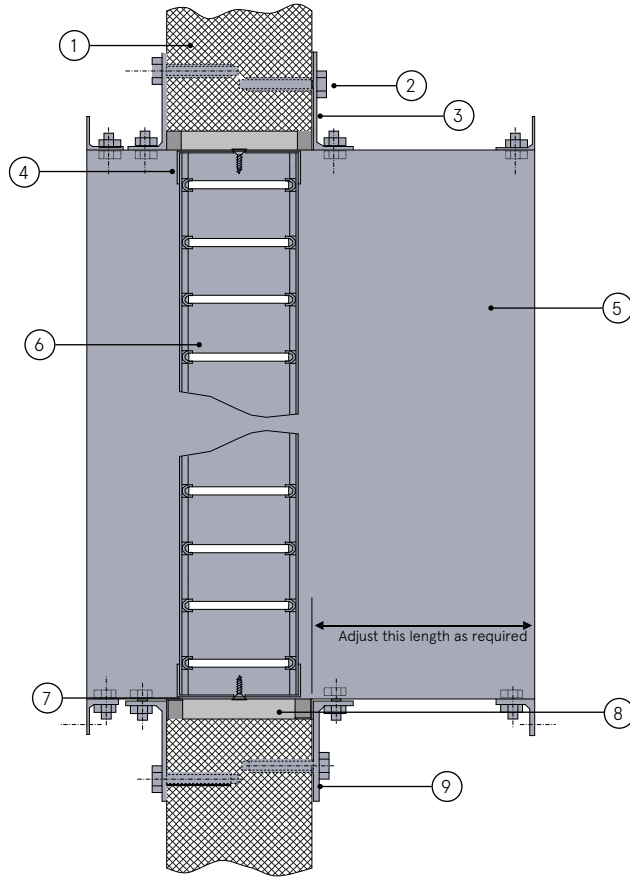

### LVH44 installation for rectangular steel duct.

## FR120

### Fire Resistance in accordance with

BS 476-22:1987

### Approval Ref

WFRC C121316

### Max single cell size

600mm x 600mm

LVH44 air transfer grilles are supplied 2mm less than the nominal size e.g. a 300mm x 300mm is actually 298mm x 298mm.

### INSTALLATION INSTRUCTIONS

- ▶ Prepare a short piece of duct at least 200mm longer than the thickness of the wall to be penetrated. (100mm wall thickness will require a minimum stub duct length of 300mm).
- ▶ To one end of the stub duct fit a wall mounting angle and a joining angle, these may welded to the ducts or screw fixed. Ensure that all mountings are correctly aligned and square with the duct stub.
- ▶ Fit the air transfer grille retaining brackets to the LVH44. Position the LVH44 into the stub duct where it will be at the centre of the section of the wall when installed e.g. 50 mm from inner flange of mounting bracket for a 100 mm thick wall.
- ▶ Fix the LVH44 using short self tapping screws through retaining brackets into duct wall.
- ▶ Seal around edge of air transfer grille with intumescent sealant.
- ▶ Cut aperture in wall at least 30 mm bigger than the outside duct dimensions.
- ▶ Place stub duct assembly into wall aperture and pack around with mineral wool ensuring that stub duct is level and correctly aligned.
- ▶ Seal over exposed wool with intumescent sealant.
- ▶ Fix mounting bracket to wall using appropriate wall fasteners.
- ▶ Slide second wall mounting bracket over duct, clamp to wall and fix using appropriate anchors.
- ▶ Fit second joining angle to end of stub duct assembly.
- ▶ Complete installation by connecting stub duct to main ducts, sealing joints with appropriate gasket material.

# DUCT 4

## LVH44 IN INSULATED DUCT SECTION

DESCRIPTION	
1	Wall
2	Wall clamping angle
3	Mineral wool packing
4	Mineral board
5	Steel duct
6	LVH44 air transfer grille
7	Joining angle
8	Damper retaining bracket 1mm galvanised steel fixed with short self tapping screws
9	Intumescent sealant - LVH44 to duct
10	Intumescent sealant bead around perimeter
11	Wall fixing angle.

**CONTENTS**

- LVH44 air transfer grille

**TOOLS REQUIRED**

- 50mm masonry anchors
- Mounting angle 75 x 25 x 1.20mm galvanised steel
- Retaining bracket 1mm (25mm x 25mm)
- Short self tapping screws (3.2mm x 16mm)
- Mineral wool
- Lorient intumescent sealant

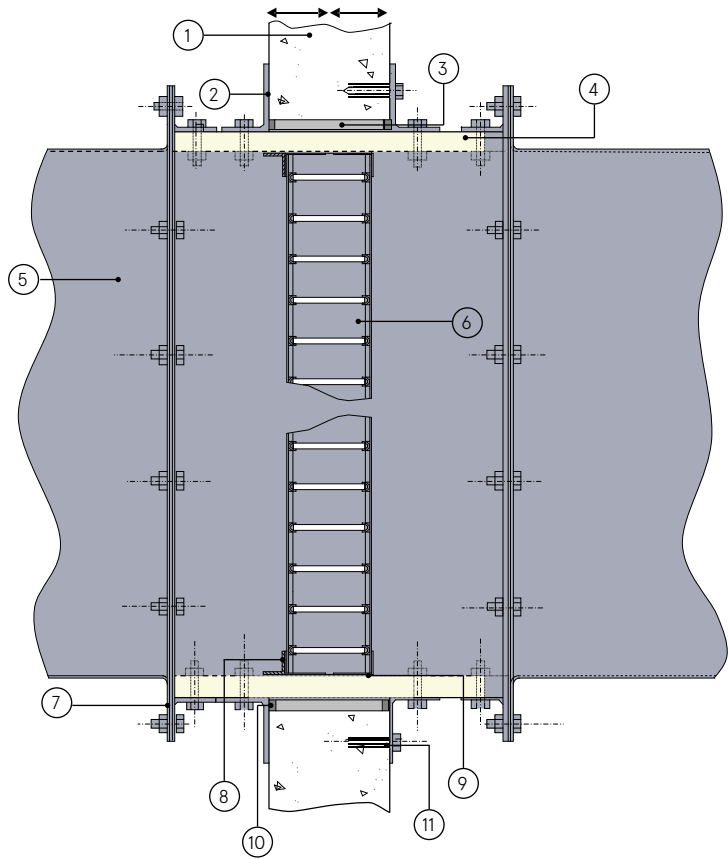

### LVH44 in insulated duct section

#### FR120

#### Fire Resistance in accordance with

BS 476-22:1987

#### Approval Ref

WFRC C121316

#### Max single cell size

600mm x 600mm

LVH44 air transfer grilles are supplied 2mm less than the nominal size e.g. a 300mm x 300mm is actually 298mm x 298mm.

### INSTALLATION INSTRUCTIONS

- ▶ Cut 20mm thick mineral boards to dimensions required ensuring a minimum of 2mm clearance on LVH44 width and height.
- ▶ Make up duct section using appropriate screws and seal any joint gaps with intumescent sealant. (Supply of the complete insulated section can be obtained from Lorient by arrangement).
- ▶ Locate damper mounting brackets around LVH44 perimeter.
- ▶ Position LVH44 in insulated duct section so that the air transfer grille will be at the mid point of the wall when the insulated duct is installed.
- ▶ Fix damper mounting brackets to inside of insulated duct using 20mm screws and seal around LVH44 with intumescent sealant.
- ▶ Fit wall mounting angles to duct using nuts and bolts (Note: the vertical flange that clamps to the wall must overlap the aperture by at least 45mm to provide a good anchorage for wall fixings).
- ▶ Pre-drill all bolt holes in insulation duct for joining angles.
- ▶ Cut aperture in wall at least 20mm greater than the dimensions of the duct outer dimensions.
- ▶ Pre-drill wall for mounting fasteners.
- ▶ Position insulated duct section into wall aperture and pack in mineral wool around periphery.
- ▶ Seal over mineral wool or any gaps with intumescent sealant.
- ▶ Secure wall fixing angle to wall using appropriate fasteners, ensuring that the angle makes even contact with the wall face and duct section is level and correctly aligned.
- ▶ Locate wall clamping angle and fix to duct with even contact to wall. Fix joining angles to insulated duct section using appropriate fasteners.
- ▶ Using appropriate gasket material, connect the main steel duct sections to the insulated duct using appropriate fasteners.



# DUCT 5

## RIGID WALL WITH ANGLE FIXINGS TO WALL (DUCT TO DUCT)

### DESCRIPTION

- 1 Rigid wall construction
  - 2 Straight through duct with breakaway connections
  - 3 LVHC44 intumescent air transfer grille
  - 4 Lorient intumescent sealant around spiral casing to a maximum clearance of 25mm
  - 5 **Fixing angle:** 40 x 40 x 1mm thick minimum galvanised steel angles fixed to LVHC44 unit with self tapping screw and to wall with masonry anchors
- Fixing option 1:** For 200mm diameter and less - 40mm wide angles, at three points on the edge of the LVHC44 air transfer grille
- Fixing option 2:** For greater than 200mm diameter 40mm wide angles, at four points on the edge of the LVHC44 air transfer grille

### CONTENTS

- LVHC44 air transfer grille

### TOOLS REQUIRED

- Fixing angle (40 x 40 x 1mm)
- Self tapping screws (3.2mm x 16mm)
- Masonry anchors
- Lorient intumescent sealant

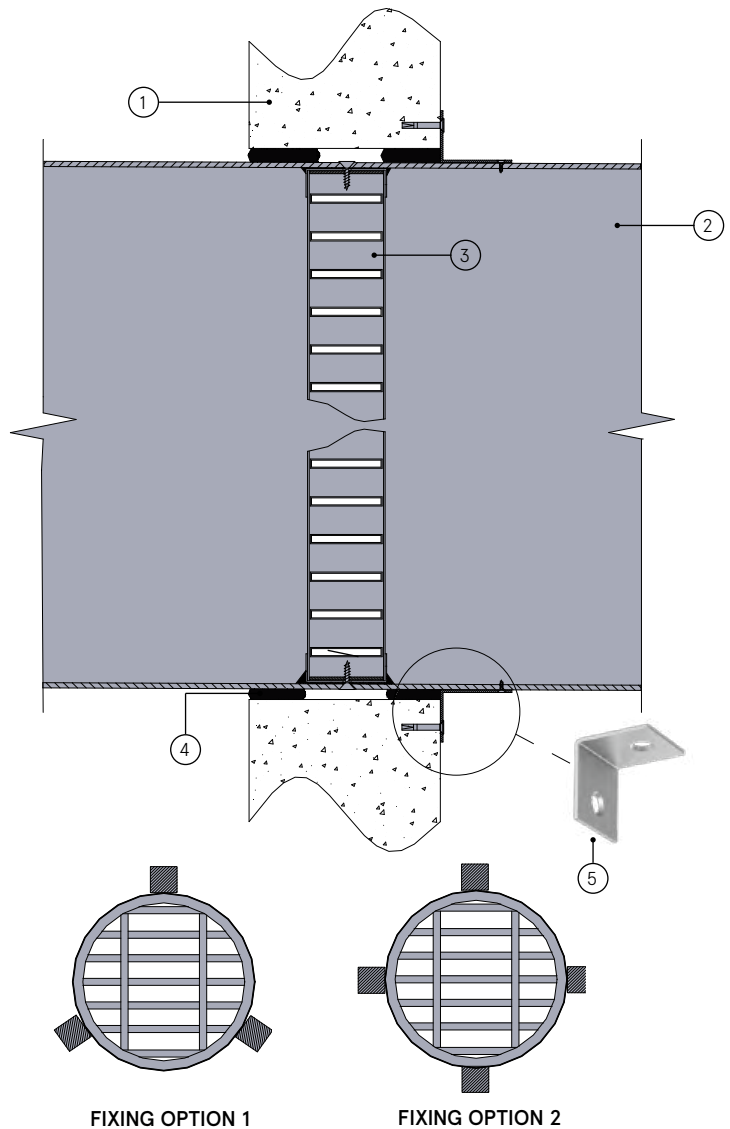

### Rigid wall with angle fixings to wall (duct to duct)

#### FR120

#### Fire Resistance in accordance with

BS 476-22:1987

#### Approval Ref

WFRC C121316 (OW1)  
WFRC 397901

#### Max single cell size

600mm diameter

LVHC44 air transfer grilles are supplied 2mm less than the nominal size e.g. a 150mm is actually 148mm.

### INSTALLATION INSTRUCTIONS

- ▶ Cut aperture in wall a least 30mm larger than the outside diameter of the duct.
- ▶ Pass duct through aperture into correct linear location and mark positions of both wall faces on duct.
- ▶ Remove duct from aperture and position LVHC44 in duct midway between the two wall marks.
- ▶ Drill through duct wall into LVHC44 outer frame and fit at least 3 number self tapping screws to retain air transfer grille.
- ▶ Seal joints between edges of LVHC44 and duct wall with intumescent sealant.
- ▶ Fix three or four mounting angles onto the LVHC44 air transfer grille unit using self tapping screws to one side only.
- ▶ Insert air transfer grille into masonry wall opening (note: LVHC44 does not have to be centrally positioned in the opening).
- ▶ Fix the three or four mounting angles depending on the diameter, to the masonry wall with masonry anchors.
- ▶ Apply a bead of Lorient intumescent sealant around the perimeter of metal sleeve as shown (note: maximum annular clearance of 25mm applies).
- ▶ Connect ductwork directly to metal sleeve using approved breakaway connections to ensure compliance.

# DUCT 6

## RIGID WALL WITH ANGLE CLAMPS (DUCT TO DUCT)

### DESCRIPTION

- 1 Rigid wall construction
- 2 Straight through duct with breakaway connections
- 3 LVHC44 intumescent air transfer grille assembly
- 4 Lorient intumescent sealant around spiral casing to a maximum clearance of 25mm
- 5 **Fixing angle:** 40 x 40 x 1mm thick minimum galvanised steel angles fixed to damper unit with TEK screw.

**Fixing option 1:** For 200mm diameter and less - 40mm wide angles, at three points on the edge of the LVHC44 fire damper.

**Fixing option 2:** For greater than 200mm diameter 40mm wide angles, at four points on the edge of the LVHC44 fire damper.

### CONTENTS

- LVHC44 air transfer grille

### TOOLS REQUIRED

- Fixing angle (40 x 40 x 1mm)
- Self tapping screws (3.2mm x 16mm)
- Lorient intumescent sealant

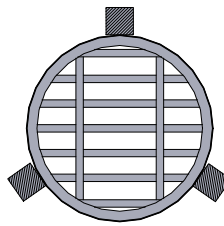
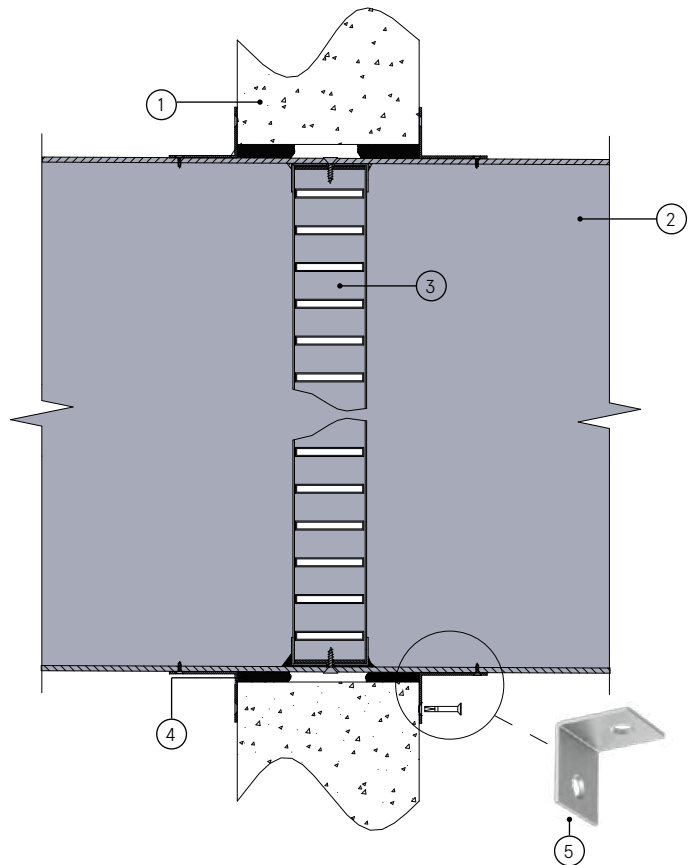

FIXING OPTION 1

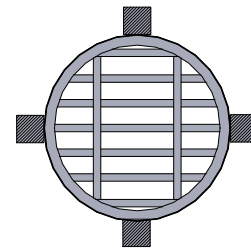

FIXING OPTION 2

### Rigid wall with angle clamps (duct to duct)

## FR120

### Fire Resistance in accordance with

BS 476-22:1987

### Approval Ref

WFRC C121316 (OW2)  
WFRC 397901

### Max single cell size

600mm diameter

LVHC44 air transfer grilles are supplied 2mm less than the nominal size e.g. a 150mm is actually 148mm.

### INSTALLATION INSTRUCTIONS

- ▶ Cut aperture in wall a least 30mm larger than the outside diameter of the duct.
- ▶ Pass duct through aperture into correct linear location and mark positions of both wall faces on duct.
- ▶ Remove duct from aperture and position LVHC44 in duct midway between the two wall marks.
- ▶ Drill through duct wall into LVHC44 outer frame and fit at least 3 number self tapping screws to retain air transfer grille.
- ▶ Seal joints between edges of LVHC44 and duct wall with intumescent sealant.
- ▶ Fix the three or four mounting angles onto one side of the LVHC44 air transfer grille unit using self tapping screws.
- ▶ Insert air transfer grille into masonry wall opening (note: LVHC44 does not have to be centrally positioned in the opening).
- ▶ Apply a bead of Lorient Intumescent sealant around the perimeter of metal sleeve as shown (note: maximum annular clearance of 25mm applies).
- ▶ Clamp the LVHC44 air transfer grille into the wall by fixing mounting angles to LVHC44 casing using self tapping screws.
- ▶ Connect ductwork directly to metal sleeve using approved breakaway connections to ensure compliance.

# DUCT 7

## FIRE RATED FLEXIBLE WALL WITH ANGLE FIXINGS TO WALL

### DESCRIPTION

- 1 Fire rated flexible wall
- 2 Straight through duct with breakaway connections
- 3 LVHC44 intumescent air transfer grille assembly
- 4 Lorient intumescent sealant around spiral casing to a maximum clearance of 25mm
- 5 **Fixing angle:** 40 x 40 x 1mm thick minimum galvanised steel angles fixed to LVHC44 unit with TEK screw and to wall with drywall screws

**Fixing option 1:** For 200mm diameter and less - 40mm wide angles, at three points on the edge of the LVHC44 air transfer grille

**Fixing option 2:** For greater than 200mm diameter 40mm wide angles, at four points on the edge of the LVHC44 air transfer grilles

### CONTENTS

- LVHC44 air transfer grille

### TOOLS REQUIRED

- Fixing angle (40 x 40 x 1mm)
- Self tapping screws (3.2mm x 16mm)
- Drywall screws
- Lorient intumescent sealant

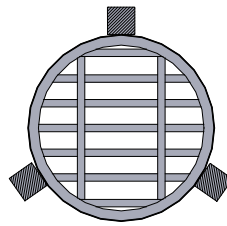
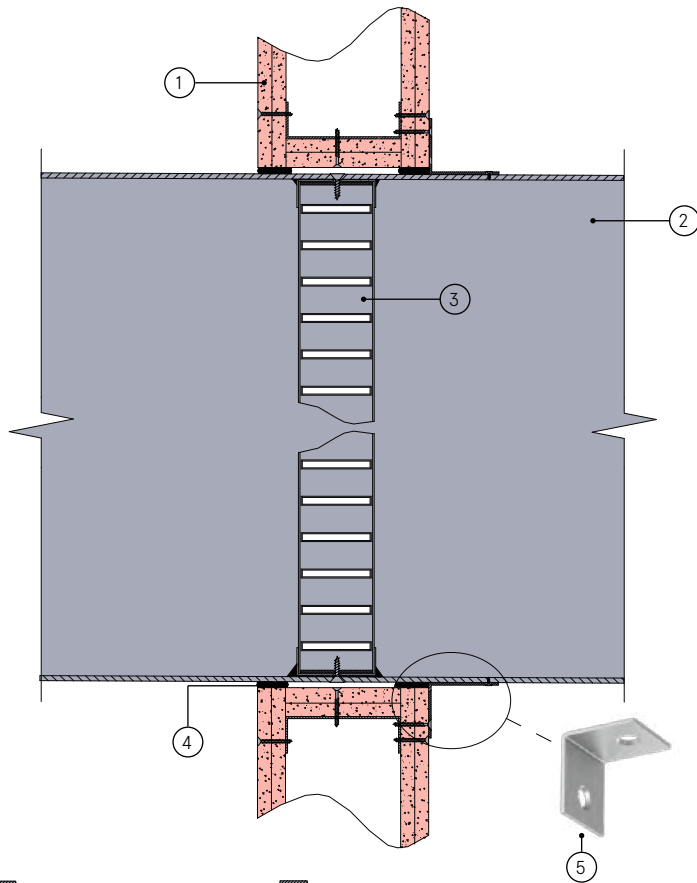

FIXING OPTION 1

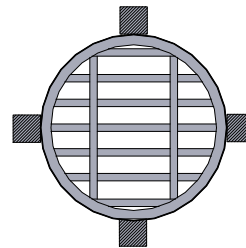

FIXING OPTION 2

### Fire rated flexible wall with angle fixings to wall

FR120

### Fire Resistance in accordance with

BS 476-22:1987

### Approval Ref

WFRC C121316 (OW3)  
WFRC 397901

### Max single cell size

600mm diameter

LVHC44 air transfer grilles are supplied 2mm less than the nominal size e.g. a 150mm is actually 148mm.

### INSTALLATION INSTRUCTIONS

- ▶ Cut aperture in wall a least 30mm larger than the outside diameter of the duct.
- ▶ Pass duct through aperture into correct linear location and mark positions of both wall faces on duct.
- ▶ Remove duct from aperture and position LVHC44 in duct midway between the two wall marks.
- ▶ Drill through duct wall into LVHC44 outer frame and fit at least 3 number self tapping screws to retain air transfer grille.
- ▶ Seal joints between edges of LVHC44 and duct wall with intumescent sealant.
- ▶ Fix three or four mounting angles onto the LVHC44 unit using self tapping screws **to one side only**.
- ▶ Insert LVHC44 into fire rated flexible wall opening (note: air transfer grille does not have to be centrally positioned in the opening).
- ▶ Fix the three or four mounting angles depending on the diameter, to the fire rated plasterboard wall with drywall screws.
- ▶ Apply a bead of Lorient intumescent sealant around the perimeter of metal sleeve as shown (note: maximum annular clearance of 25mm applies).
- ▶ Connect ductwork directly to metal sleeve using approved breakaway connections to ensure compliance.

# DUCT 8

## FIRE RATED FLEXIBLE WALL WITH ANGLE CLAMPS

### DESCRIPTION

- 1 Fire rated flexible wall
  - 2 Straight through duct with breakaway connections
  - 3 LVHC44 intumescent air transfer grille assembly
  - 4 Lorient intumescent sealant around spiral casing to a maximum clearance of 25mm
  - 5 **Fixing angle:** 40 x 40 x 1mm thick minimum galvanised steel angles fixed to air transfer grille unit with self tapping screws
- Fixing option 1:** For 200mm diameter and less - 40mm wide angles, at three points on the edge of the LVHC44 air transfer grille
- Fixing option 2:** For greater than 200mm diameter 40mm wide angles, at four points on the edge of the LVHC44 air transfer grille

### CONTENTS

- LVHC44 air transfer grille

### TOOLS REQUIRED

- Fixing angle (40 x 40 x 1mm)
- Self tapping screws (3.2mm x 16mm)
- Drywall screws
- Lorient intumescent sealant

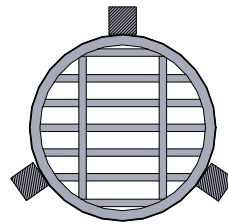
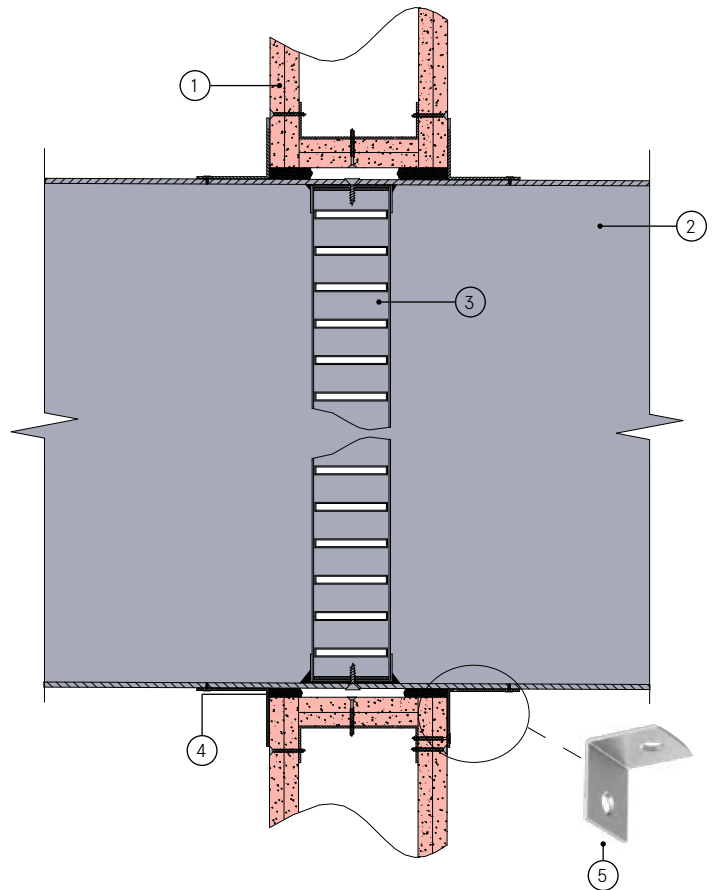

FIXING OPTION 1

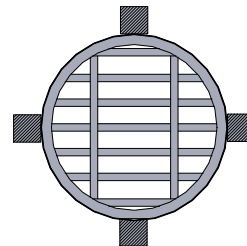

FIXING OPTION 2

### Fire rated flexible wall with angle clamps

## FR120

### Fire Resistance in accordance with

BS 476-22:1987

### Approval Ref

WFRC C121316 (OW4)  
WFRC 397901

### Max single cell size

600mm diameter

LVHC44 air transfer grilles are supplied 2mm less than the nominal size e.g. a 150mm is actually 148mm.

### INSTALLATION INSTRUCTIONS

- ▶ Cut aperture in wall a least 30mm larger than the outside diameter of the duct.
- ▶ Pass duct through aperture into correct linear location and mark positions of both wall faces on duct.
- ▶ Remove duct from aperture and position LVHC44 in duct midway between the two wall marks.
- ▶ Drill through duct wall into LVHC44 outer frame and fit at least 3 number self tapping screws to retain air transfer grille.
- ▶ Seal joints between edges of LVHC44 and duct wall with intumescent sealant.
- ▶ Fix the three or four mounting angles onto one side of the LVHC44 air transfer grille unit using self tapping screws.
- ▶ Insert LVHC44 into fire rated flexible wall opening (note: air transfer grille does not have to be centrally positioned in the opening).
- ▶ Apply a bead of Lorient intumescent sealant around the perimeter of metal sleeve as shown (note: maximum annular clearance of 25mm applies).
- ▶ Clamp the LVHC44 into the wall by fixing mounting angles to LVHC44 casing using self tapping screws.
- ▶ Connect ductwork directly to metal sleeve using approved breakaway connections to ensure compliance.

# DUCT 9

## RIGID WALL WITH ANGLE FIXINGS (DUCT TO GRILLE)

### DESCRIPTION

- 1 Rigid wall construction
- 2 Straight through duct with breakaway connections
- 3 LVHC44 air transfer grille
- 4 Cover grille
- 5 Lorient intumescent sealant around spiral casing to a maximum clearance of 25mm
- 6 **Fixing angle:** 40 x 40 x 1mm thick minimum galvanised steel angles fixed to air transfer grille unit with self tapping screws and to wall with masonry anchors

**Fixing option 1:** For 200mm diameter and less - 40mm wide angles, at three points on the edge of the LVHC44 air transfer grille

**Fixing option 2:** For greater than 200mm diameter - 40mm wide angles, at four points on the edge of the LVHC44 air transfer grille

### CONTENTS

- LVHC44 air transfer grille

### TOOLS REQUIRED

- Fixing angle (40 x 40 x 1mm)
- Self tapping screws (3.2mm x 16mm)
- Masonry anchors
- Lorient intumescent sealant

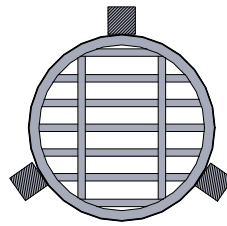
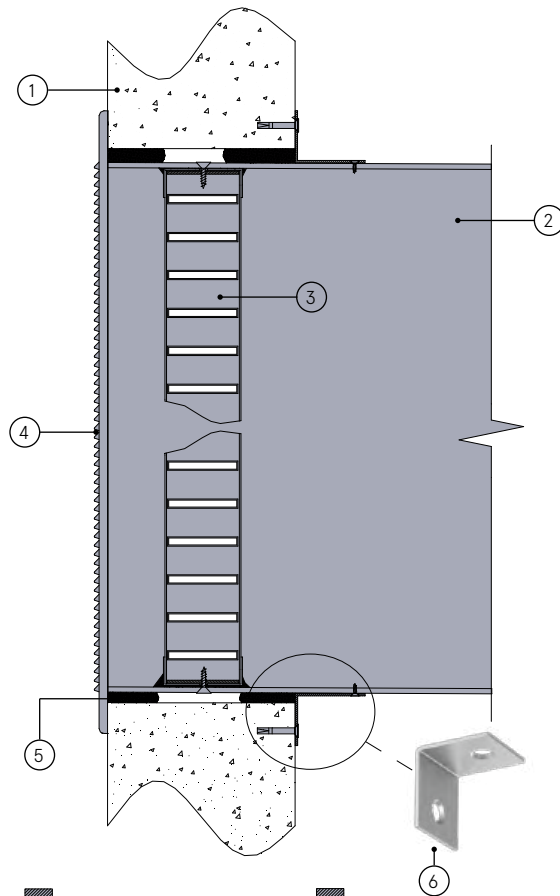

FIXING OPTION 1

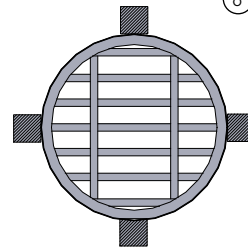

FIXING OPTION 2

### Rigid wall with angle fixings (duct to grille)

## FR120

### Fire Resistance in accordance with

BS 476-22:1987

### Approval Ref

WFRC C121316 (OW5)  
WFRC 397901

### Max single cell size

600mm diameter

LVHC44 air transfer grilles are supplied 2mm less than the nominal size e.g. a 150mm is actually 148mm.

### INSTALLATION INSTRUCTIONS

- ▶ Cut aperture in wall a least 30mm larger than the outside diameter of the duct.
- ▶ Pass duct through aperture into correct linear location and mark positions of both wall faces on duct.
- ▶ Remove duct from aperture and position LVHC44 in duct midway between the two wall marks.
- ▶ Drill through duct wall into LVHC44 outer frame and fit at least 3 number self tapping screws to retain air transfer grille.
- ▶ Seal joints between edges of LVHC44 and duct wall with intumescent sealant.
- ▶ Fix the three or four mounting angles onto the LVHC44 air transfer grille unit using self tapping screws to **one side only**.
- ▶ Insert air transfer grille into masonry wall opening (note: LVHC44 does not have to be centrally positioned in the opening).
- ▶ Fix the three or four mounting angles depending on the diameter, to the masonry wall with masonry anchors.
- ▶ Cut protruding galvanised steel casing to be flush with face of wall.
- ▶ Apply a bead of Lorient intumescent sealant around the perimeter of metal sleeve as shown (note: maximum annular clearance of 25mm applies).
- ▶ Connect cover grille/ductwork directly to metal sleeve using approved breakaway connections to ensure compliance.

# DUCT 10

## RIGID WALL CONSTRUCTION (DUCT TO DUCT)

DESCRIPTION	
1	Rigid wall construction
2	Straight through duct with breakaway connections
3	Mounting angles
4	LVH44 air transfer grille
5	Damper retaining bracket 1mm galvanised steel fixed with short self tapping screws
6	M5 securing bolts
7	Seal around edge of air transfer grille with intumescent sealant
8	Fill any gaps between the LVH44 and wall opening with Lorient intumescent sealant

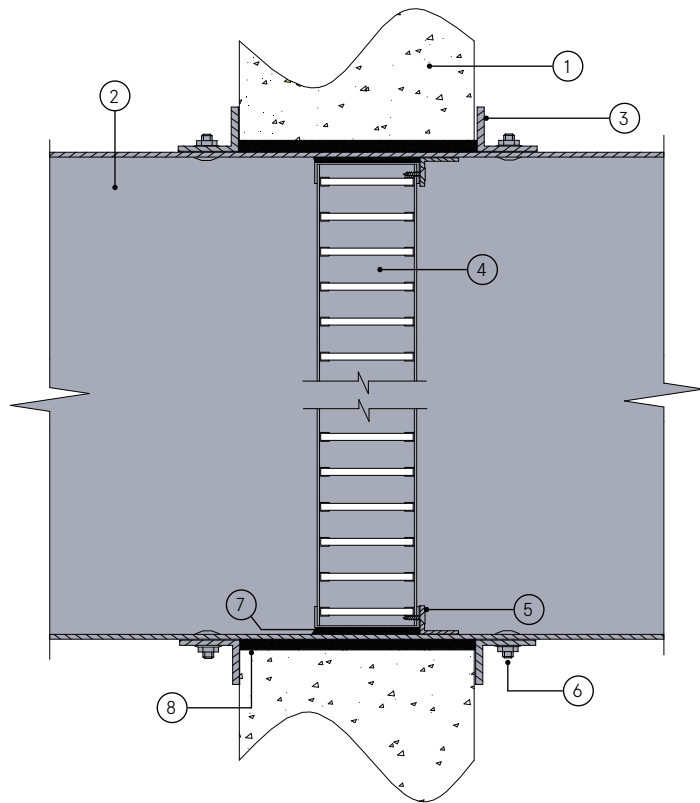

### CONTENTS

- LVH44 air transfer grille

### TOOLS REQUIRED

- Drill & 5mm bit
- M5 bolts
- Self tapping screws (3.2mm x 16mm)
- Mounting angles (40 x 40 x 2mm)
- Lorient intumescent sealant

### Rigid wall construction (duct to duct)

## FR120

### Fire Resistance in accordance with

BS 476-22:1987

### Approval Ref

WFRC C121316 (W-Series)

### Max single cell size

600mm x 600mm

LVH44 air transfer grilles are supplied 2mm less than the nominal size e.g. a 300mm x 300mm is actually 298mm x 298mm.

### INSTALLATION INSTRUCTIONS

- ▶ Prepare a short piece of duct at least 200mm longer than the thickness of the wall to be penetrated. (100mm wall thickness will require a minimum stub duct length of 300mm).
- ▶ To one end of the stub duct fit a wall mounting angle and a joining angle, these may be welded to the ducts or screw fixed. Ensure that all mountings are correctly aligned and square with the stub duct.
- ▶ Fit the air transfer grille retaining brackets to the LVH44. Position the LVH44 into the stub duct where it will be at the centre of the section of the wall when installed e.g. 50 mm from inner flange of mounting bracket for a 100 mm thick wall.
- ▶ Fix the LVH44 using short self tapping screws through retaining brackets.
- ▶ Seal around edge of air transfer grille with intumescent sealant.
- ▶ Make an opening in the wall.
- ▶ Check the mounting flange size is not less than twice the clearance between the LVH44 and opening.
- ▶ Insert air transfer grille into wall opening.
- ▶ Check the casing fully penetrates the wall opening.
- ▶ Tighten bolts on one set of mounting angles, ensuring the LVH44 sits squarely in the wall.
- ▶ Fill any gaps between the LVH44 and wall opening with Lorient intumescent sealant.
- ▶ Fit mounting flanges on opposite side of wall, ensuring the flanges are hard against the wall and the fixings are adequately tightened.
- ▶ Check the air transfer grille assembly sits squarely in the opening.
- ▶ Connect ductwork to casing, using approved breakaway connections to ensure compliance.
- ▶ Ensure convenient access is provided for easy inspection and cleaning as necessary.

# DUCT 11

## FIRE RATED FLEXIBLE WALL (DUCT TO DUCT)

### DESCRIPTION

- |   |  |
|---|--|
| 1 | Fire rated flexible wall   |
| 2 | Straight through duct with breakaway connections                                   |
| 3 | Mounting angles  |
| 4 | LVH44 air transfer grille  |
| 5 | Damper retaining bracket 1mm galvanised steel fixed with short self tapping screws |
| 6 | M5 securing bolts  |
| 7 | Seal around edge of air transfer grille with intumescent sealant                   |
| 8 | Fill any gaps between the LVH44 and wall opening with Lorient intumescent sealant  |

### CONTENTS

- LVH44 air transfer grille

### TOOLS REQUIRED

- Drill & 5mm bit
- M5 bolts
- Self tapping screws (3.2mm x 16mm)
- Mounting angles (40 x 40 x 2mm)
- Lorient intumescent sealant

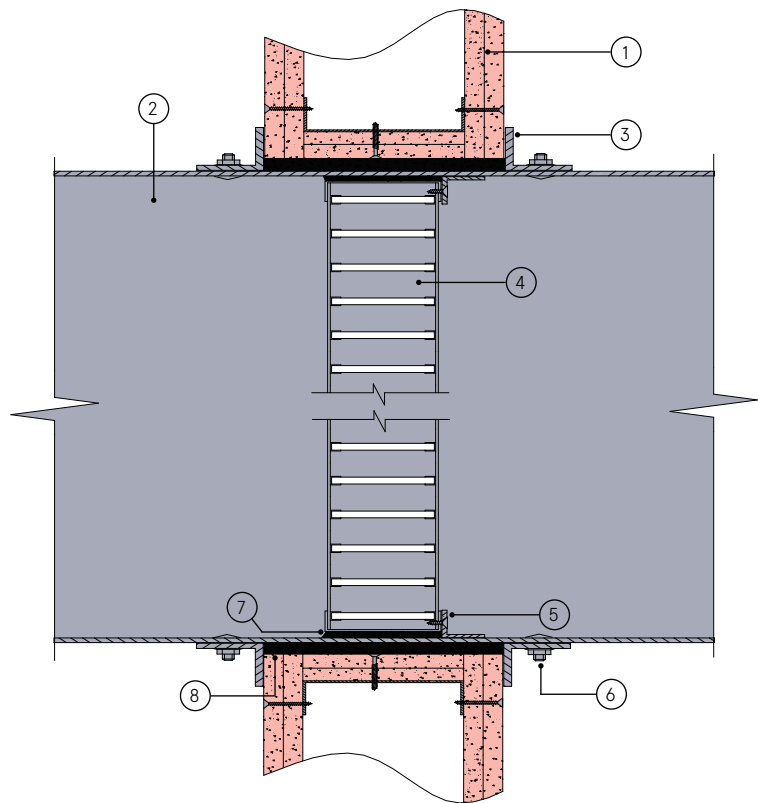

### Fire rated flexible wall (duct to duct)

## FR120

### Fire Resistance in accordance with

BS 476-22:1987

### Approval Ref

WFRC C121316 (W-Series)

### Max single cell size

600mm x 600mm

LVH44 air transfer grilles are supplied 2mm less than the nominal size e.g. a 300mm x 300mm is actually 298mm x 298mm.

### INSTALLATION INSTRUCTIONS

- ▶ Prepare a short piece of duct at least 200mm longer than the thickness of the wall to be penetrated. (100mm wall thickness will require a minimum stub duct length of 300mm).
- ▶ To one end of the stub duct fit a wall mounting angle and a joining angle, these may be welded to the ducts or screw fixed. Ensure that all mountings are correctly aligned and square with the stub duct.
- ▶ Fit the air transfer grille retaining brackets to the LVH44. Position the LVH44 into the stub duct where it will be at the centre of the section of the wall when installed e.g. 50 mm from inner flange of mounting bracket for a 100 mm thick wall.
- ▶ Fix the LVH44 using short self tapping screws through retaining brackets.
- ▶ Seal around edge of air transfer grille with intumescent sealant.
- ▶ Make an opening in the wall.
- ▶ Check the mounting flange size is not less than twice the clearance between the air transfer grille and opening.
- ▶ Insert LVH44 into wall opening.
- ▶ Check the casing fully penetrates the wall opening.
- ▶ Tighten bolts on one set of mounting angles, ensuring the LVH44 sits squarely in the wall.
- ▶ Fill any gaps between the air transfer grille and wall opening with Lorient intumescent sealant.
- ▶ Fit mounting flanges on opposite side of wall, ensuring the flanges are hard against the wall and the fixings are adequately tightened.
- ▶ Check the air transfer grille assembly sits squarely in the opening.
- ▶ Connect ductwork to casing, using approved breakaway connections to ensure compliance.
- ▶ Ensure convenient access is provided for easy inspection and cleaning as necessary.



# DUCT 12

## FIRE RATED FLEXIBLE WALL (DUCT TO GRILLE)

### DESCRIPTION

- |   |  |
|---|--|
| 1 | Fire rated flexible wall   |
| 2 | Flanged duct with breakaway connection   |
| 3 | Mounting angles  |
| 4 | M5 securing bolts  |
| 5 | LVH44 air transfer grille  |
| 6 | Lorient RVCV steel face fixed cover grille   |
| 7 | Damper retaining bracket 1mm galvanised steel fixed with short self tapping screws |
| 8 | Seal around edge of air transfer grille with intumescent sealant                   |
| 9 | Fill any gaps between the LVH44 and wall opening with Lorient intumescent sealant  |

### CONTENTS

- LVH44 air transfer grille

### TOOLS REQUIRED

- Drill & 5mm bit
- M5 bolts
- Self tapping screws (3.2mm x 16mm)
- Mounting angles (40 x 40 x 2mm)
- Lorient intumescent sealant

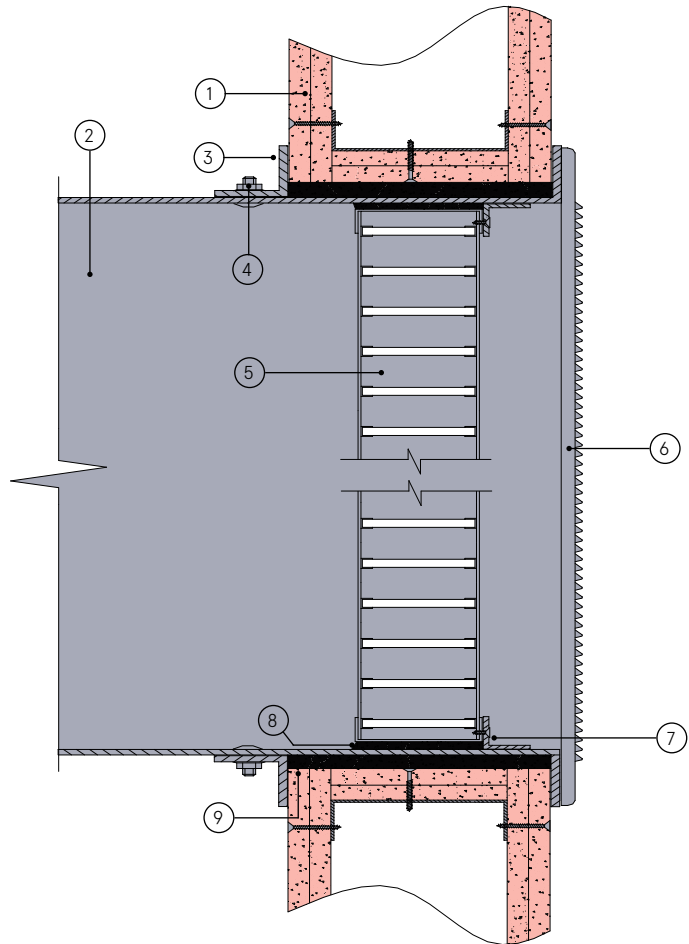

### Fire rated flexible wall (duct to grille)

## FR120

### Fire Resistance in accordance with

BS 476-22:1987

### Approval Ref

WFRC C121316 (W-Series)

### Max single cell size

600mm x 600mm

LVH44 air transfer grilles are supplied 2mm less than the nominal size e.g. a 300mm x 300mm is actually 298mm x 298mm.

### INSTALLATION INSTRUCTIONS

- ▶ Prepare a short piece of duct at least 100mm longer than the thickness of the wall to be penetrated. (100mm wall thickness will require a minimum stub duct length of 200mm).
- ▶ To one end of the stub duct fit a wall mounting angle and a joining angle, these may be welded to the ducts or screw fixed. Ensure that all mountings are correctly aligned and square with the stub duct.
- ▶ Fit the air transfer grille retaining brackets to the LVH44. Position the LVH44 into the stub duct where it will be at the centre of the section of the wall when installed e.g. 50mm from inner flange of mounting bracket for a 100mm thick wall.
- ▶ Fix the LVH44 using short self tapping screws through retaining brackets.
- ▶ Seal around edge of air transfer grille with intumescent sealant.
- ▶ Make an opening in the wall.
- ▶ Check the mounting flange size is not less than twice the clearance between the air transfer grille and opening.
- ▶ Insert LVH44 into fire rated flexible wall opening.
- ▶ Check the casing fully penetrates the wall opening.
- ▶ Fill any gaps between the LVH44 and wall opening with Lorient intumescent sealant.
- ▶ Fit mounting flanges and ensure flanges are hard against the wall and the fixings are adequately tightened.
- ▶ Check the air transfer grille assembly sits squarely in the opening.
- ▶ Connect ductwork to casing, using approved breakaway connections to ensure compliance.
- ▶ Ensure convenient access is provided for easy inspection and cleaning as necessary.

# DUCT 13

## RIGID WALL WITH METAL CASING (DUCT TO GRILLE)

### DESCRIPTION

- |   |  |
|---|--|
| 1 | Rigid wall construction  |
| 2 | Flanged duct with breakaway connection   |
| 3 | Mounting angles  |
| 4 | M5 securing bolts  |
| 5 | LVH44 air transfer grille  |
| 6 | Lorient RVCG steel face fixed cover grille   |
| 7 | Damper retaining bracket 1mm galvanised steel fixed with short self tapping screws |
| 8 | Seal around edge of air transfer grille with intumescent sealant                   |
| 9 | Fill any gaps between the LVH44 and wall opening with Lorient intumescent sealant  |

### CONTENTS

- LVH44 air transfer grille

### TOOLS REQUIRED

- Drill & 5mm bit
- M5 bolts
- Self tapping screws (3.2mm x 16mm)
- Mounting angles (40 x 40 x 2mm)
- Lorient intumescent sealant

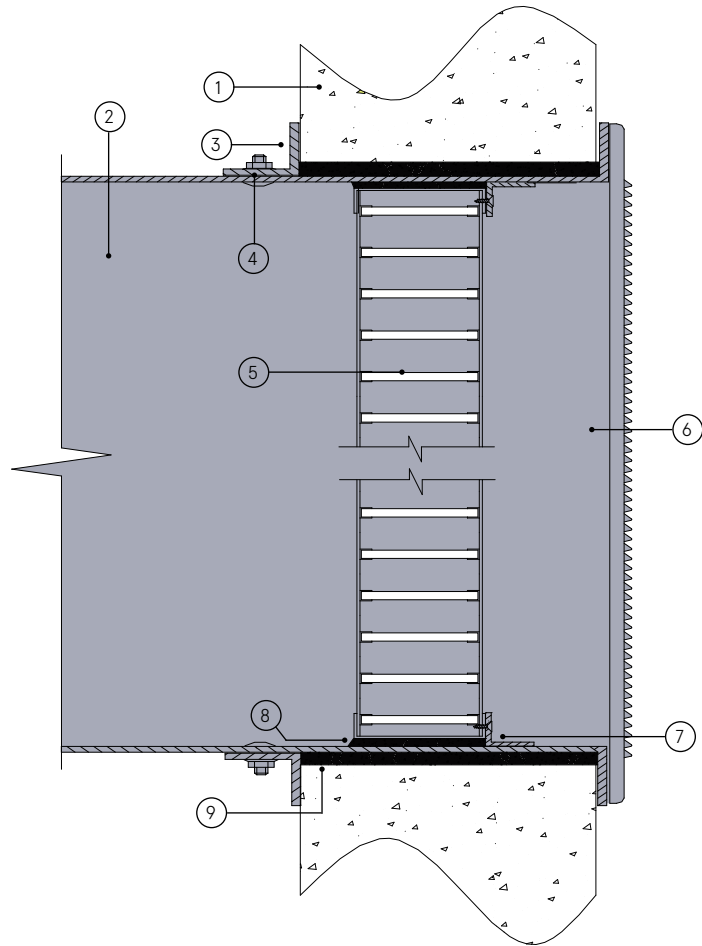

### Rigid wall with metal casing (duct to grille)

## FR120

### Fire Resistance in accordance with

BS 476-22:1987

### Approval Ref

WFRC C121316 (W-Series)

### Max single cell size

600mm x 600mm

LVH44 air transfer grilles are supplied 2mm less than the nominal size e.g. a 300mm x 300mm is actually 298mm x 298mm.

### INSTALLATION INSTRUCTIONS

- ▶ Prepare a short piece of duct at least 100mm longer than the thickness of the wall to be penetrated. (100mm wall thickness will require a minimum stub duct length of 200mm).
- ▶ To one end of the stub duct fit a wall mounting angle and a joining angle, these may be welded to the ducts or screw fixed. Ensure that all mountings are correctly aligned and square with the stub duct.
- ▶ Fit the air transfer grille retaining brackets to the LVH44. Position the LVH44 into the stub duct where it will be at the centre of the section of the wall when installed e.g. 50mm from inner flange of mounting bracket for a 100mm thick wall.
- ▶ Fix the LVH44 using short self tapping screws through retaining brackets.
- ▶ Seal around edge of air transfer grille with intumescent sealant.
- ▶ Make an opening in the wall.
- ▶ Check the mounting flange size is not less than twice the clearance between the air transfer grille and opening.
- ▶ Insert LVH44 assembly into masonry wall opening.
- ▶ Check the casing fully penetrates the wall opening.
- ▶ Fill any gaps between the air transfer grille and wall opening with Lorient intumescent sealant.
- ▶ Fit mounting flanges and ensure flanges are hard against the wall and the fixings are adequately tightened.
- ▶ Check the air transfer grille assembly sits squarely in the opening.
- ▶ Connect ductwork to casing, using approved breakaway connections to ensure compliance.
- ▶ Ensure convenient access is provided for easy inspection and cleaning as necessary.

# DUCT 14

## LVH54 INSTALLATION FOR RECTANGULAR STEEL DUCT

### DESCRIPTION

- | DESCRIPTION  |
|--|
| 1 4 x 65mm wide graphite based intumescent backing pad   |
| 2 70 x 30 x 3mm steel clamping plates fixed to duct with M5 nuts and bolts   |
| 3 45 x 45 x 3mm standard steel flanges   |
| 4 25 x 25 x 1.5mm steel LVH54 retaining frames fixed with M3 counter sunk bolts and nuts                                     |
| 5 1.4 mm thick galvanised steel stub duct with continuous welded seam  |
| 6 LVH54 air transfer grille bedded in Lorient intumescent sealant  |
| 7 65mm anchor bolts  |
| 8 Mineral fibre packing between duct and blockwork   |
| 9 Using Lorient intumescent sealant, bed the LVH54 into the position into stub duct against the pre-fitted retaining flange. |

### CONTENTS

- LVH54 air transfer grille

### TOOLS REQUIRED

- Graphite based intumescent backing pad
- 70 x 30 x 3mm steel clamping plates
- M5 nuts and bolts
- M3 nuts and bolts
- 65mm anchor bolts
- 45 x 45 x 3mm standard steel flanges
- 25 x 25 x 1.5mm steel LVH54 retaining frames
- Lorient intumescent sealant

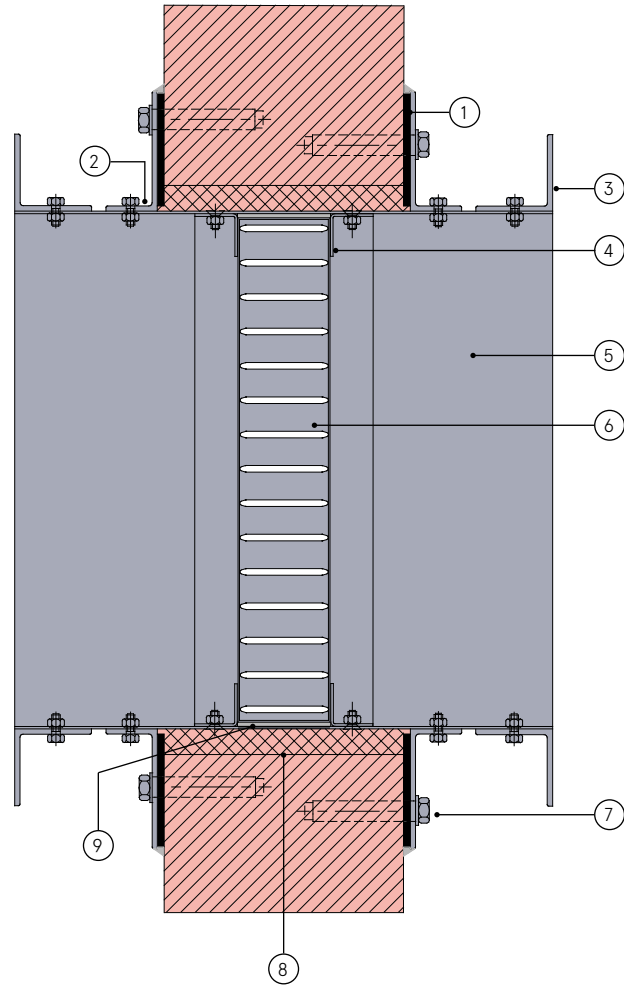

### LVH54 installation for rectangular steel duct.

## E240 EI30

### Fire Resistance in accordance with

ISO 10294-5

### Approval Ref

BRE 227730

### Max single cell size

600mm x 600mm

LVH54 air transfer grilles are supplied 2mm less than the nominal size e.g. a 300mm x 300mm is actually 298mm x 298mm.

### INSTALLATION INSTRUCTIONS

- ▶ Prepare a short piece of duct at least 200mm longer than the thickness of the wall to be penetrated. (100mm wall thickness will require a minimum stub duct length of 300mm).
- ▶ Position a LVH54 retaining flange square within the stub duct and fix so that the LVH54 will be in the mid position of the duct length. It is imperative that the LVH54 must be located within the thickness of the wall regardless of the position of the stub duct.
- ▶ Fit a clamping plate to the stub duct exterior, offset from the mid point by half the thickness of the wall.
- ▶ Cut to size 8 no. pieces of Lorient intumescent sheet material and fix 4 no. to the flange of the pre-fitted clamping plate using self adhesive tape in order to provide a continuous seal between the clamping plate flange and the wall.
- ▶ Using Lorient intumescent sealant, bed the LVH54 into the position into stub duct against the pre-fitted retaining flange. Fit the second retaining flange ensuring all gaps around the edge of the LVH54 are filled with intumescent sealant.
- ▶ Cut an aperture in the wall at least 30mm bigger than the outside duct dimension. (If the aperture has been cut more than 60mm greater than the duct external dimension, then the wall must be made good to the appropriate size before attempting to fit the stub duct assembly).
- ▶ Position the stub duct assembly into the aperture and tightly pack around with mineral wool and seal exposed wool with intumescent sealant. Press the pre-fitted clamping plate and intumescent sheet seal hard against the wall. Fix the pre-fitted clamping plate flange to the wall ensuring the intumescent sheet seal is deployed satisfactorily.
- ▶ Fix the 4 remaining sheet seals with self adhesive tape to the flange of the second clamping plate and position over stub duct up to wall and fix in place making sure that the duct is positioned square to the wall in both planes. Seal over all exposed mineral wool with intumescent sealant.
- ▶ Fit standard jointing flanges to each end of the stub duct and complete the installation by connecting the stub duct to the main duct, sealing joints with appropriate gasket materials.

# DUCT 15

## LVHCTD + LVH44/LVH54 IN RECTANGULAR STEEL DUCT

**DESCRIPTION**

1	Wall
2	4mm x 65mm wide Lorient graphite based backing pads
3	Prefitted clamping plate
4	65mm anchor bolts
5	70 x 30 x 3mm steel clamping plate fixed to duct with M5 nuts & bolts
6	45 x 45 x 3mm standard steel flanges
7	Sliding shutter plate & actuator assembly
8	LVH44 or LVH54 air transfer grille for fire and cold smoke control or no air transfer grille for cold smoke control only – as per specification
9	Intumescent sealant seal over mineral fibre face
10	Mineral fibre packing
11	Aluminium bolts to fasten duct joint flanges (approx. melting point 540 deg.C).

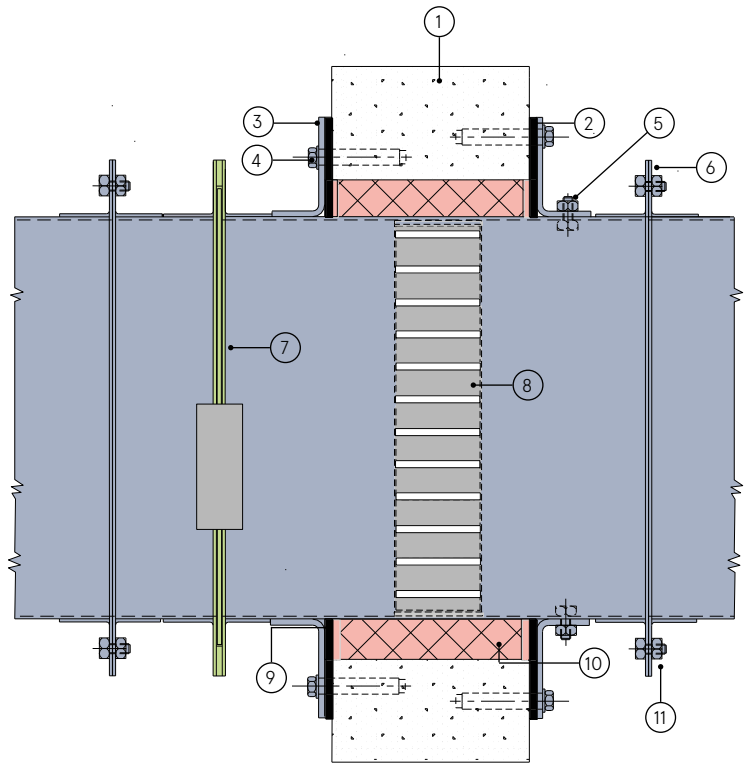

**CONTENTS**

- LVHCTD + LVH44/LVH54 air transfer grille

**TOOLS REQUIRED**

- Graphite based intumescent backing pad

- 70 x 30 x 3mm steel clamping plates
- M5 nuts and bolts

- M3 nuts and bolts
- 65mm anchor bolts
- 45 x 45 x 3mm standard steel flanges

- 25 x 25 x 1.5mm steel LVH retaining frames
- Lorient intumescent sealant

### LVHCTD + LVH44\*/LVH54\*\* installation for rectangular steel duct. FR120\*/FR240\*

**Fire Resistance in accordance with**

BS 476-22:1987\*

ISO 10294-5\*\*

**Approval Ref**

WFRC C121316\*

BRE 227730\*\*

**Max single cell size**

600mm x 600mm.

LVH44/LVH54 air transfer grilles are supplied 2mm less than the nominal size e.g. a 300mm x 300mm is actually 298mm x 298mm.

**INSTALLATION INSTRUCTIONS**

- ▶ **This product is primarily designed for installation in the orientation shown; any proposed change to the plane of operation should be discussed with Lorient technical staff in advance.**
- ▶ Cut an aperture in the wall at least 30mm bigger than the outside LVHCTD casing dimension in a position that will allow the smoke control shutter plate to be slid out of the housing. (If the aperture has been cut more than 60mm greater than the casing dimension, then the wall must be made good to the appropriate size before attempting to fit the LVHCTD assembly).
- ▶ For fire rated air transfer grilles cut to size 8 no. pieces of Lorient rigid graphite based intumescent sheet material and fix 4 no. to the flange of the pre-fitted clamping plate using self adhesive tape in order to provide a continuous seal between the clamping plate flange and the wall. Cold smoke control 'only' LVHCTD do not need these seals.
- ▶ Position the assembly into the aperture taking care that the smoke control shutter plate can slide clear of the housing without interference from the surroundings, tightly pack around with mineral wool and seal both exposed faces of the mineral wool with intumescent sealant.
- ▶ Press the pre-fitted clamping plate and where fitted the intumescent sheet seal hard against the wall. Care must be taken to avoid distorting the

assembly by crushing or twisting. Fix the pre-fitted clamping plate flange to the wall ensuring the intumescent sheet seal if fitted is deployed satisfactorily.

- ▶ For fire rated LVHCTD fix the 4 remaining sheet seals with self adhesive tape to the flange of the second clamping plate and position over the casing up to wall and fix in place making sure that the duct is positioned square to the wall in both planes. Seal over all exposed mineral wool with intumescent sealant.
- ▶ Ensure that the inside of the housing and shutter plates are entirely clear of dust and debris.
- ▶ Fit standard jointing flanges to each end of the housing and complete the installation by connecting to the duct, sealing joints with appropriate gasket materials.
- ▶ Check that the shutter plate assembly can slide freely within the housing.
- ▶ The electrical connections for the actuator of the cold smoke control system must be made in accordance with the instructions contained in Talkback Manual. Test the function of the system in accordance with the installing and commissioning instructions supplied with the LVHCTD.

# INDEPENDENT DUCT CONNECTION ALTERNATIVES

**B1**

Bed angles on Lorient  
intumescent sealant  
to ensure an airtight  
seal between  
ductwork and wall.

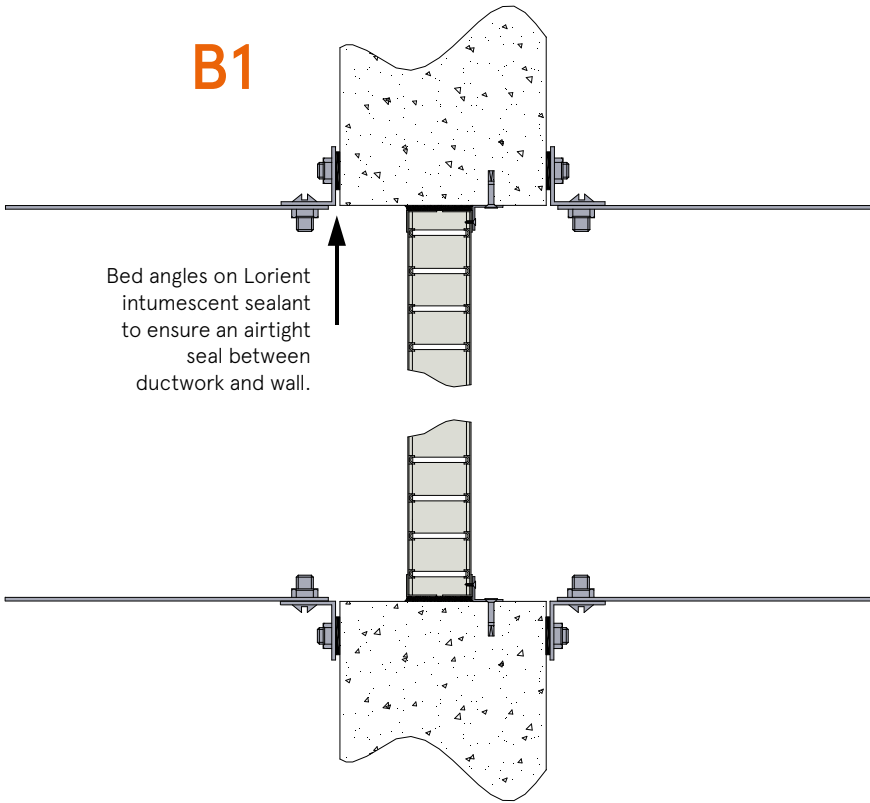

**B2**

Bed channels on  
Lorient intumescent  
sealant to ensure an  
airtight seal between  
ductwork and wall.

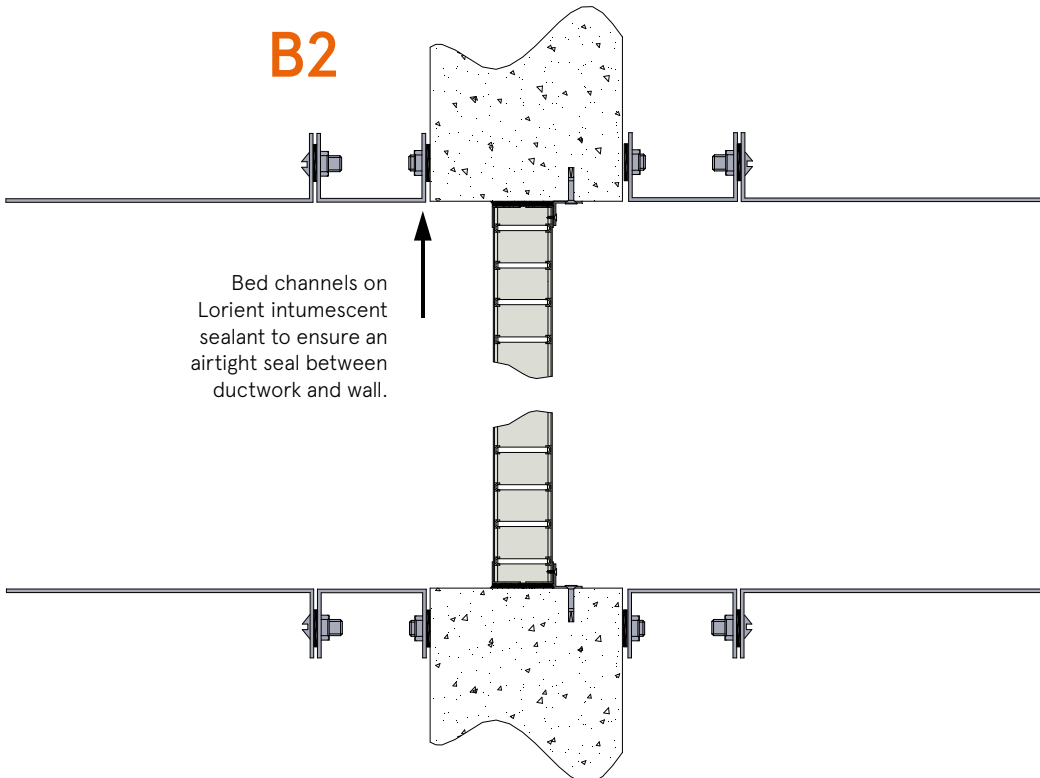

# INDEPENDENT DUCT CONNECTION ALTERNATIVES

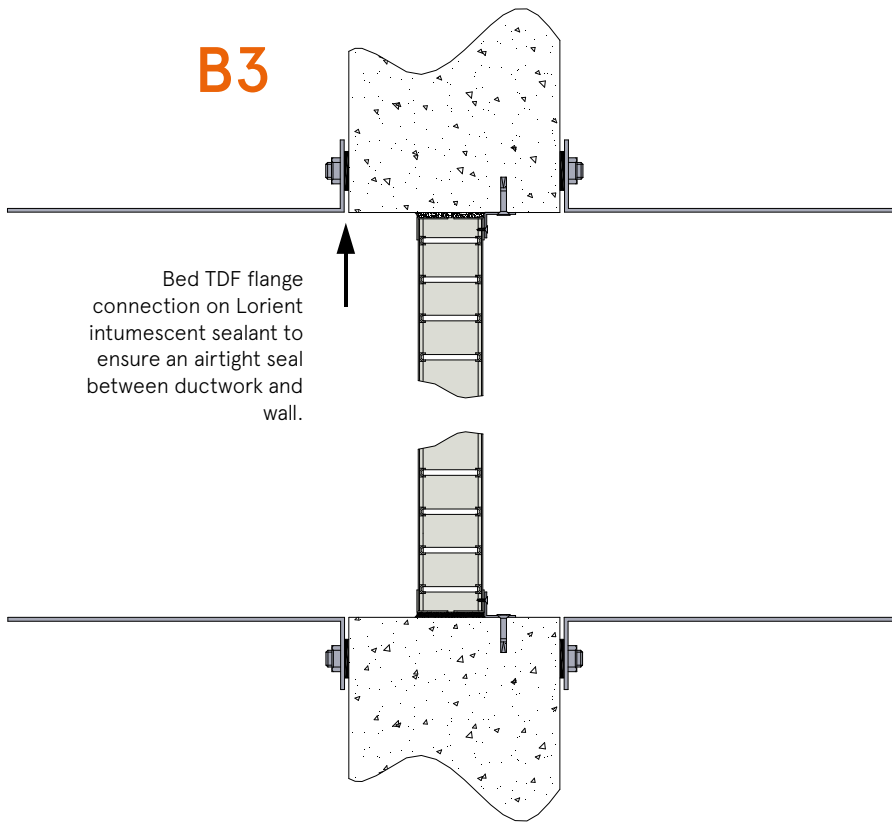

# FLOOR MOUNTED SYSTEMS

System		Fire Rating	Application	Product	Page No.
Floor 1	▲	FR120	Masonry floor with angle fixings	LVHC44	
Floor 2	▲	FR120	Masonry floor with angle clamps	LVHC44	
Floor 3	▲	FR120	Masonry floor with angle fixings	LVH44	
Floor 4	▲	FR120	Masonry floor with Z section fixings	LVH44	
Floor 5	▲	FR120	Masonry floor using pre-cast slab to suit	LVH44	
Floor 6	▲	FR120	Fixing on top of masonry floors with angle fixings	LVH44	
Floor 7	▲	FR120	Modular system for masonry floors	LVH44	
Floor 8	▲	FR120	Modular system for fixing on top of masonry floors	LVH44	
Floor 9	▲	FR120	Masonry floor (duct to duct)	LVH44	
Floor 10	▲	FR120	Masonry floor (duct to grille)	LVH44	

# FLOOR 1

## MASONRY FLOOR WITH ANGLE FIXINGS

### DESCRIPTION

- 1 Independent duct fixing complete with breakaway joints
  - 2 Lorient intumescent sealant around spiral casing to a maximum clearance of 10mm
  - 3 LVHC44 air transfer grille
  - 4 Supporting angles (25 x 25 x 1mm)
  - 5 **Fixing angle:** 40 x 40 x 1mm thick minimum galvanised steel angles fixed to LVHC44 unit with self tapping screws and to wall with masonry anchors
- Fixing option 1 - for less than 200mm diameter:** supporting/mounting angles, at three points on the edge of the LVHC44 air transfer grille
- Fixing option 2 - for greater than 200mm diameter:** supporting/mounting angles, at four points on the edge of the LVHC44 air transfer grille

### CONTENTS

- LVHC44 air transfer grille

### TOOLS REQUIRED

- Self tapping screw (3.2mm x 16mm)
- Supporting angles 25 x 25 x 1mm
- Mounting angles 40 x 40 x 1mm
- Lorient intumescent sealant

**Note:** If no reticulating ductwork is above the slab a protective and load-bearing grate is necessary.

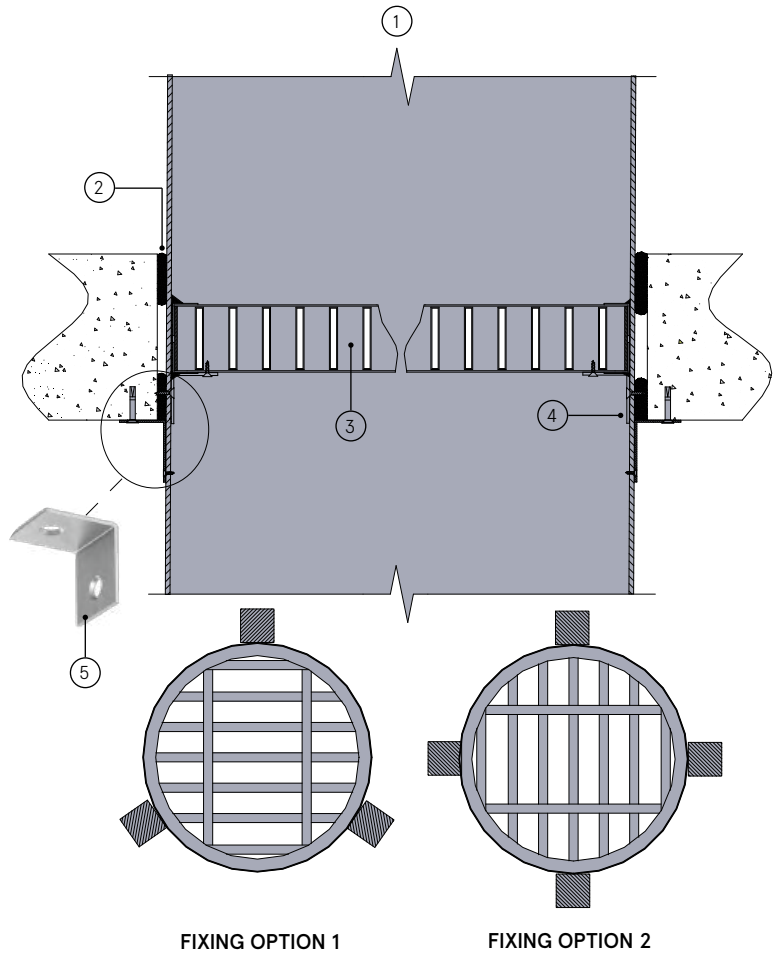

### Masonry floor with angle fixings

## FR120

### Fire Resistance in accordance with

BS 476-22:1987

### Approval Ref

WFRC C121316 (OF1)

### Max single cell size

600mm diameter

LVHC44 air transfer grilles are supplied 2mm less than the nominal size e.g. a 300mm is actually 298mm.

### INSTALLATION INSTRUCTIONS

- ▶ Fix the three or four supporting angles into the duct section using self tapping screws.
- ▶ Fix the LVHC44 into duct and seal around the perimeter with intumescent sealant.
- ▶ Fix to supporting angles with 3.2 x 16mm self tapping screws.
- ▶ Fix the three or four mounting angles onto the outside of the duct section using self tapping screws.
- ▶ Insert air transfer grille into masonry floor opening (note: LVHC44 does not have to be centrally positioned in the opening).
- ▶ Fix the three or four mounting angles depending on the diameter, to the masonry floor with masonry anchors.
- ▶ Apply a bead of Lorient intumescent sealant around the perimeter of metal sleeve as shown (note: maximum annular clearance of 10mm applies).
- ▶ Connect ductwork directly to metal sleeve using approved breakaway connections to ensure compliance.



# FLOOR 2

## MASONRY FLOOR WITH ANGLE CLAMPS

### DESCRIPTION

- 1 Independent duct fixing complete with breakaway joints
- 2 LVHC44 air transfer grille
- 3 Lorient intumescent sealant around spiral casing to a maximum clearance of 10mm
- 4 Supporting angles (25 x 25 x 1mm)
- 5 **Fixing angle:** 40 x 40 x 1mm thick minimum galvanised steel angles fixed to LVHC44 unit with self tapping screws

**Fixing option 1 - for less than 200mm diameter:** supporting/mounting angles, at three points on the edge of the LVHC44 air transfer grille

**Fixing option 2 - for greater than 200mm diameter:** supporting/mounting angles, at four points on the edge of the LVHC44 air transfer grille

### CONTENTS

- LVHC44 air transfer grille

### TOOLS REQUIRED

- Self tapping screw (3.2mm x 16mm)
- Supporting angles 25 x 25 x 1mm
- Mounting angles 40 x 40 x 1mm
- Lorient intumescent sealant

**Note:** If no reticulating ductwork is above the slab a protective and load-bearing grate is necessary.

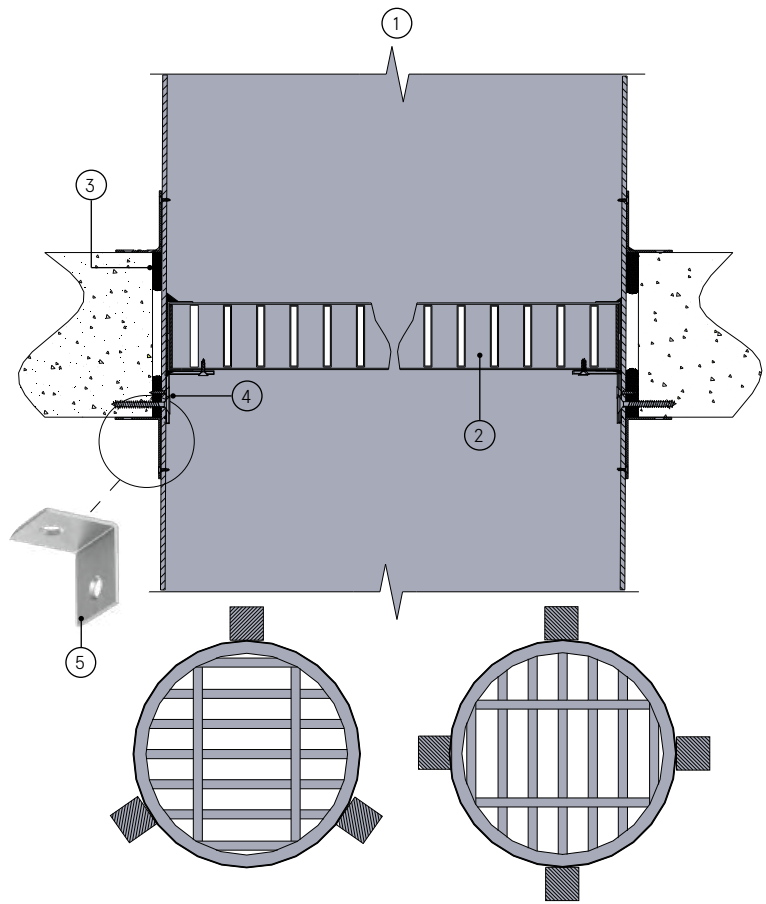

FIXING OPTION 1

FIXING OPTION 2

### Masonry floor with angle clamps

## FR120

### Fire Resistance in accordance with

BS 476-22:1987

### Approval Ref

WFRC C121316 (OF2)

### Max single cell size

600mm diameter

LVHC44 air transfer grilles are supplied 2mm less than the nominal size e.g. a 300mm is actually 298mm.

### INSTALLATION INSTRUCTIONS

- ▶ Fix the three or four supporting angles into the duct section using self tapping screws.
- ▶ Fix the LVHC44 into duct and seal around the perimeter with intumescent sealant.
- ▶ Fix to supporting angles with 3.2 x 16mm self tapping screws.
- ▶ Fix the three or four mounting angles onto the outside of the duct section using self tapping screws.
- ▶ Insert air transfer grille into masonry floor opening (note: LVHC44 does not have to be centrally positioned in the opening).
- ▶ Clamp the LVHC44 into the floor by fixing mounting angles to duct section on other side of floor using self tapping screws.
- ▶ Apply a bead of Lorient intumescent sealant around the perimeter of metal sleeve as shown (note: maximum annular clearance of 10mm applies).
- ▶ Connect ductwork directly to metal sleeve using

approved breakaway connections to ensure compliance.

# FLOOR 3

## MASONRY FLOOR WITH ANGLE FIXINGS

### DESCRIPTION

- 1 Masonry floor
  - 2 LVH44 air transfer grille
  - 3 Lorient intumescent sealant around LVH44 perimeter to a maximum clearance of 10mm
  - 4 **Fixing angle:** 40 x 20 x 1mm thick minimum galvanised steel angles fixed to floor with masonry anchors
- Fixing option 1:** Full width angles on opposing sides only with 200mm fixing centres
- Fixing option 2:** 20mm wide angles, central to all four sides or at 200mm maximum centres.

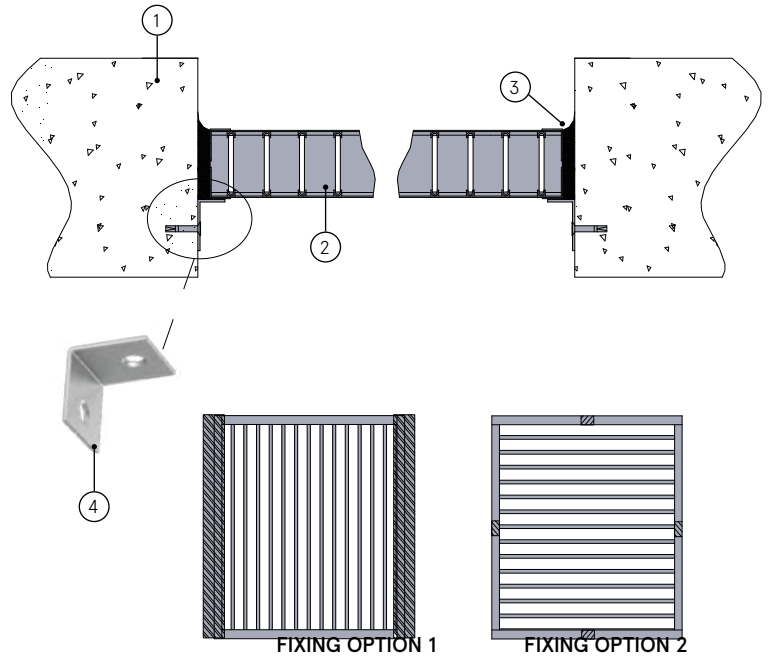

### CONTENTS

- LVH44 air transfer grille

### TOOLS REQUIRED

- Masonry anchors
- Angle fixings 40 x 20 x 1mm
- Lorient intumescent sealant

**Note:** If no reticulating ductwork is above the slab a protective and load-bearing grate is necessary.

### Masonry floor with angle fixings

## FR120

### Fire Resistance in accordance with

BS 476-22:1987

### Approval Ref

WFRC C121316 (AF1)

### Max single cell size

600 x 600mm

Larger sizes can be used with different mounting detail.

LVH44 air transfer grilles are supplied 2mm less than the nominal size e.g. a 300mm x 300mm is actually 298mm x 298mm.

### INSTALLATION INSTRUCTIONS

- ▶ Fix the mounting angles to the masonry floor using masonry anchors to **one side only**.
- ▶ Insert LVH44 into masonry floor opening (note: air transfer grille does not have to be centrally positioned in the opening).
- ▶ Apply a bead of Lorient intumescent sealant around the perimeter of metal sleeve as shown (note: maximum annular clearance of 10mm applies).
- ▶ Connect ductwork (or cover grille) directly to floor using approved breakaway connections to ensure compliance.

# FLOOR 4

## MASONRY FLOOR WITH Z SECTION FIXINGS

### DESCRIPTION

- 1 Masonry floor
- 2 LVH44 air transfer grille
- 3 Lorient intumescent sealant around LVH44 perimeter to a maximum clearance of 10mm
- 4 **Fixing angle:** 40 x 60 x 20mm, 1mm thick minimum galvanised steel Z sections fixed to floor with masonry anchors

**Fixing option 1:** Full width Z sections on opposing sides only with 200mm fixing centres

**Fixing option 2:** 20mm wide Z sections, central to all four sides or at 200mm maximum centres.

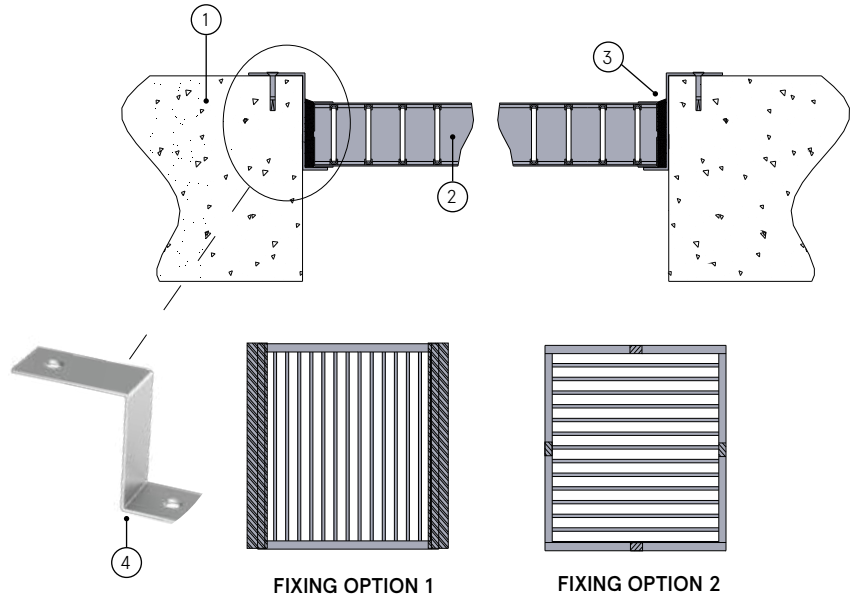

### CONTENTS

- LVH44 air transfer grille

### TOOLS REQUIRED

- Lorient intumescent sealant
- Masonry anchors
- Z section fixings 40 x 60 x 20mm, 1mm thick



Note: If no reticulating ductwork is above the slab a protective and load-bearing grate is necessary.

### Masonry floor with Z section fixings

## FR120

### Fire Resistance in accordance with

BS 476-22:1987

### Approval Ref

WFRC C121316 (AF2)

### Max single cell size

600 x 600mm

Larger sizes can be used with different mounting detail.

LVH44 air transfer grilles are supplied 2mm less than the nominal size e.g. a 300mm x 300mm is actually 298mm x 298mm.

### INSTALLATION INSTRUCTIONS

- ▶ Fix the Z sections to the masonry floor using masonry anchors.
- ▶ Insert LVH44 into masonry floor opening (note: air transfer grille does not have to be centrally positioned in the opening).
- ▶ Apply a bead of Lorient intumescent sealant around the perimeter of metal sleeve as shown (note: maximum clearance of 10mm applies).
- ▶ Connect ductwork (or cover grille) directly to floor using approved breakaway connections to ensure compliance.

# FLOOR 5

## MASONRY FLOOR USING PRE-CAST SLAB TO SUIT

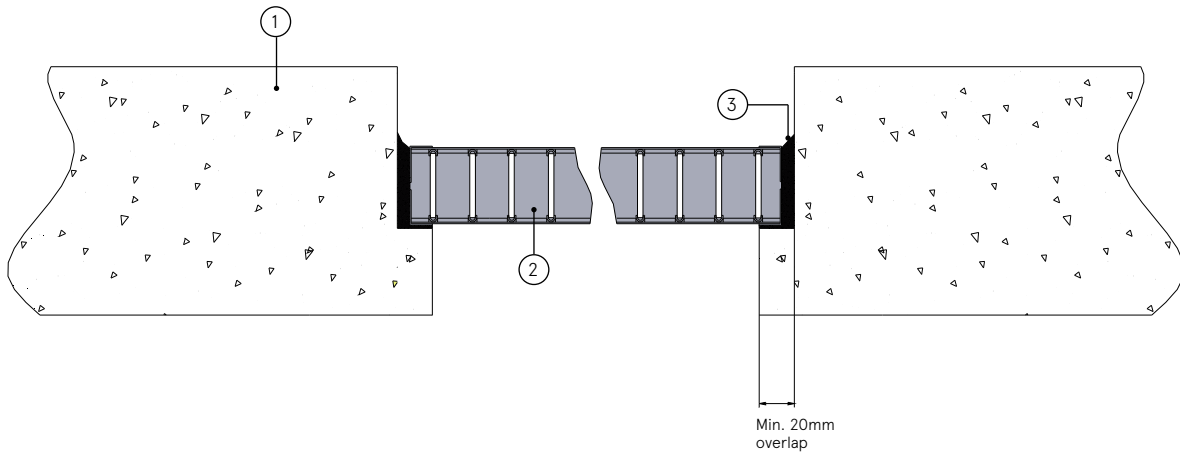

### DESCRIPTION

- 1 Pre-cast concrete slab
- 2 LVH44 air transfer grille
- 3 Lorient intumescent sealant around LVH44 perimeter to a maximum clearance of 10mm

### CONTENTS

- LVH44 air transfer grille

### TOOLS REQUIRED

- Lorient intumescent sealant

 Note: If no reticulating ductwork is above the slab a protective and load-bearing grate is necessary.

## Masonry floor using pre-cast slabs to suit FR120

### Fire Resistance in accordance with

BS 476-22:1987

### Approval Ref

WFRC C121316 (AF3)

### Max single cell size

600 x 600mm

Larger sizes can be used with different mounting detail.

LVH44 air transfer grilles are supplied 2mm less than the nominal size e.g. a 300mm x 300mm is actually 298mm x 298mm.

### INSTALLATION INSTRUCTIONS

- ▶ Prepare slab with cast in ledges (minimum 20mm overlap of ledge with LVH44).
- ▶ Mount LVH44 onto masonry floor opening.
- ▶ Apply a bead of Lorient intumescent sealant around the perimeter of air transfer grille between the LVH44 and the floor (note: maximum clearance of 10mm applies).
- ▶ Connect ductwork (or cover grille) directly to floor using approved breakaway connections to ensure compliance.

# FLOOR 6

## FIXING ON TOP OF MASONRY FLOORS WITH ANGLE FIXINGS

### DESCRIPTION

- 1 Masonry floor
- 2 LVH44 air transfer grille
- 3 Apply a bead of Lorient intumescent sealant around the edge of the LVH44
- 4 **Fixing angle:** 40 x 40 x 1mm thick minimum galvanised steel angles fixed to LVH44 unit with self tapping screws and to wall with masonry anchors

**Fixing option 1:** Full width angles top and bottom only with 200mm fixing centres

**Fixing option 2: (Ideal for fire rating poorly prepared openings):** Angles central to all four sides or at 200mm maximum centres

### CONTENTS

- LVH44 air transfer grille

### TOOLS REQUIRED

- Lorient intumescent sealant
- Self tapping screws (3.2mm x 16mm)
- Masonry anchors
- Fixing angle (40 x 40 x 1mm)

**Note:** If no reticulating ductwork is above the slab a protective and load-bearing grate is necessary.

### FIXING OPTION 1

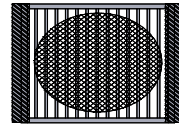

### FIXING OPTION 2

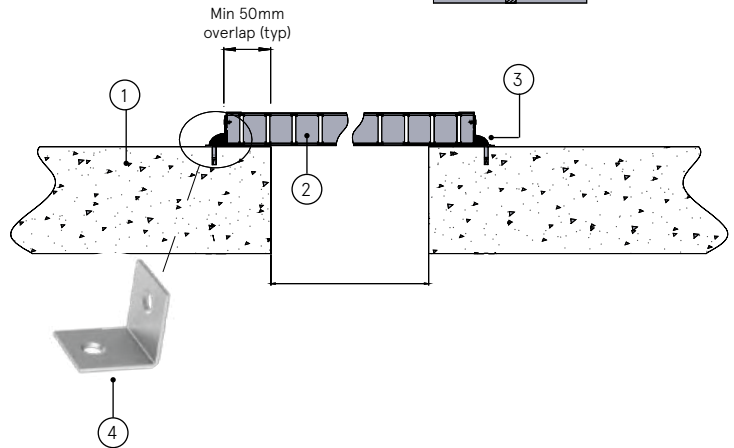
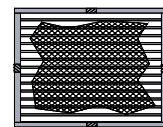

### Fixing on top of masonry floors with angle fixings

## FR120

### Fire Resistance in accordance with

BS 476-22:1987

### Approval Ref

WFRC C121316 (AF5)

### Max single cell size

600 x 600mm

LVH44 air transfer grilles are supplied 2mm less than the nominal size e.g. a 300mm x 300mm is actually 298mm x 298mm.

### INSTALLATION INSTRUCTIONS

- ▶ Measure penetration ensuring air transfer grille is 50mm larger than penetration in masonry floor.
- ▶ Fix the mounting angles onto the LVH44 unit using self tapping screws.
- ▶ Apply a bead of Lorient intumescent sealant around the edge of the LVH44.
- ▶ Mount air transfer grille onto masonry floor opening.
- ▶ Fix the angles to the masonry floor with masonry anchors.
- ▶ Connect ductwork (or cover grille) directly to floor using approved breakaway connections to ensure compliance.

# FLOOR 7 MODULAR SYSTEMS

## FOR MASONRY FLOORS

### DESCRIPTION

- 1 Use fixing systems below to mount modular LVH44 in floor:
  - ▶ Floor 3
  - ▶ Floor 4
  - ▶ Floor 5
- 2 Insert Lorient intumescent sealant between modules
- 3 For modular systems a 10mm (min) clearance around perimeter is required
- 4 Air transfer grille locates within tab sections

### CONTENTS

- LVH44 air transfer grille

### TOOLS REQUIRED

- Lorient intumescent sealant
- Self tapping screws (3.2 x 16mm)
- Masonry anchors

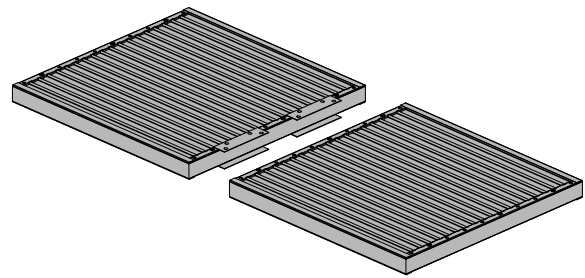
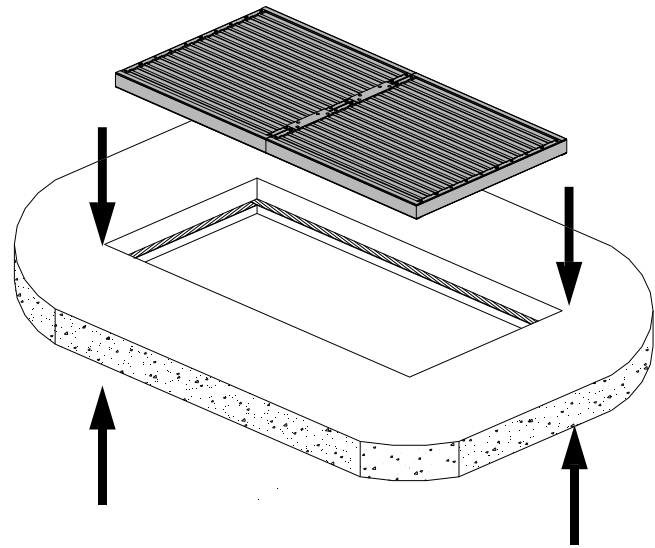

▶▶ Note: If no reticulating ductwork is above the slab a protective and load-bearing grate is necessary.

### Masonry floor modular system

## FR120

### Fire Resistance in accordance with

BS 476-22:1987

### Approval Ref

WFRC C121316 (AF6)

### Max single cell size

1200 x 600mm

Please consult the Lorient Technical team for larger sizes

LVH44 air transfer grilles are supplied 2mm less than the nominal size e.g. a 300mm x 300mm is actually 298mm x 298mm.

### INSTALLATION INSTRUCTIONS

This system can be installed using any one of the following three Systems:

**Floor 3: ANGLE FIXING DETAIL** (using continuous perimeter angles are required)

**Floor 4: Z SECTION FIXING DETAIL** (using continuous perimeter angles are required)

**Floor 5: PRE-CAST SLAB FIXING DETAIL**

- ▶ Slide the air transfer grille modules together ensuring a bead of Lorient intumescent sealant is used in between LVH44 modules (secure with self tapping screws).
- ▶ Refer to the relevant systems above for specific mounting detail alternatives.
- ▶ Apply bead of Lorient intumescent sealant around perimeter of LVH44 between air transfer grille and floor.
- ▶ Fix the angles to the masonry floor with masonry anchors.

# FLOOR 8 MODULAR SYSTEMS

## FIXING ON TOP OF MASONRY FLOORS WITH ANGLE FIXINGS

### DESCRIPTION

- 1 Masonry floor
- 2 LVH44 air transfer grille
- 3 Apply a bead of Lorient intumescent sealant around the edge of the LVH44
- 4 **Fixing angle:** 40 x 40 x 1mm thick minimum galvanised steel angles fixed to LVH44 unit with self tapping screws and to wall with masonry anchors to entire perimeter.

### CONTENTS

- LVH44 air transfer grille

### TOOLS REQUIRED

- Lorient intumescent sealant
- Self tapping screws (3.2mm x 16mm)
- Masonry anchors
- Fixing angle (40 x 40 x 1mm)

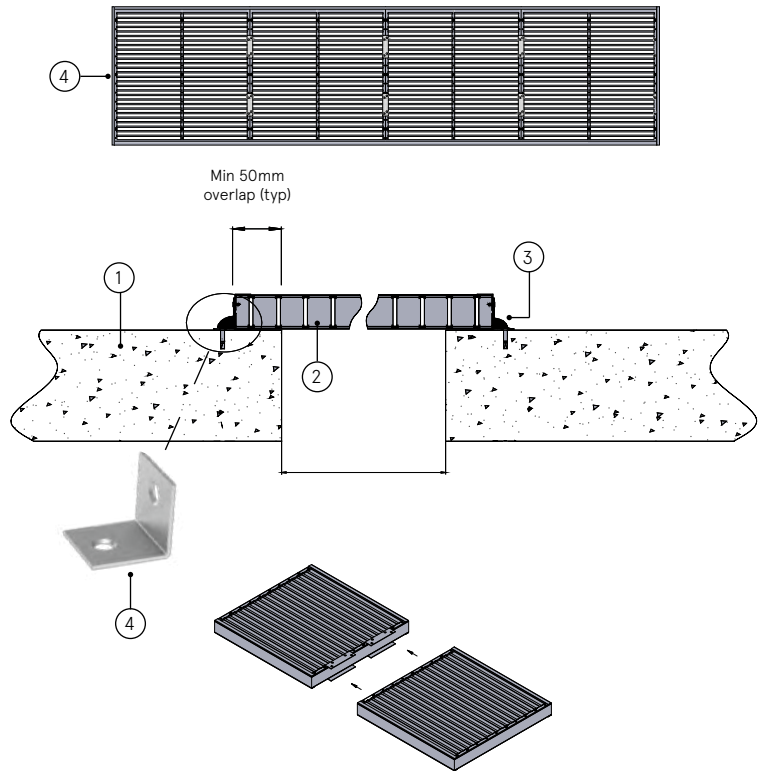

▶▶ Note: If no reticulating ductwork is above the slab a protective and load-bearing grate is necessary.

### Fixing on top of masonry floors with angle fixings

#### FR120

#### Fire Resistance in accordance with

BS 476-22:1987

#### Approval Ref

WFRC C121316 (AF7)

#### Max single cell size

2400 x 600mm

LVH44 air transfer grilles are supplied 2mm less than the nominal size e.g. a 300mm x 300mm is actually 298mm x 298mm.

### INSTALLATION INSTRUCTIONS

- ▶ Measure penetration ensuring air transfer grille is 50mm larger than penetration in masonry floor.
- ▶ Slide the air transfer grille modules together ensuring a bead of Lorient intumescent sealant is used in between LVH44 modules (secure with self tapping screws).
- ▶ Fix the mounting angles onto the LVH44 unit using self tapping screws.
- ▶ Apply a bead of Lorient intumescent sealant around the edge of the LVH44.
- ▶ Mount air transfer grille onto masonry floor opening.
- ▶ Fix the angles to the masonry floor with masonry anchors.

# FLOOR 9

## MASONRY FLOOR (DUCT TO DUCT)

### DESCRIPTION

- |   |  |
|---|--|
| 1 | Independent duct fixing complete with breakaway joints                             |
| 2 | Light gauge galvanised casing  |
| 3 | Damper retaining bracket 1mm galvanised steel fixed with short self tapping screws |
| 4 | Mounting angles  |
| 5 | LVH44 air transfer grille inclusive of casing                                      |
| 6 | M5 bolts for mounting angles.  |
| 7 | Lorient intumescent sealant between casing and concrete slab                       |
| 8 | Lorient intumescent sealant between LVH44 and casing                               |

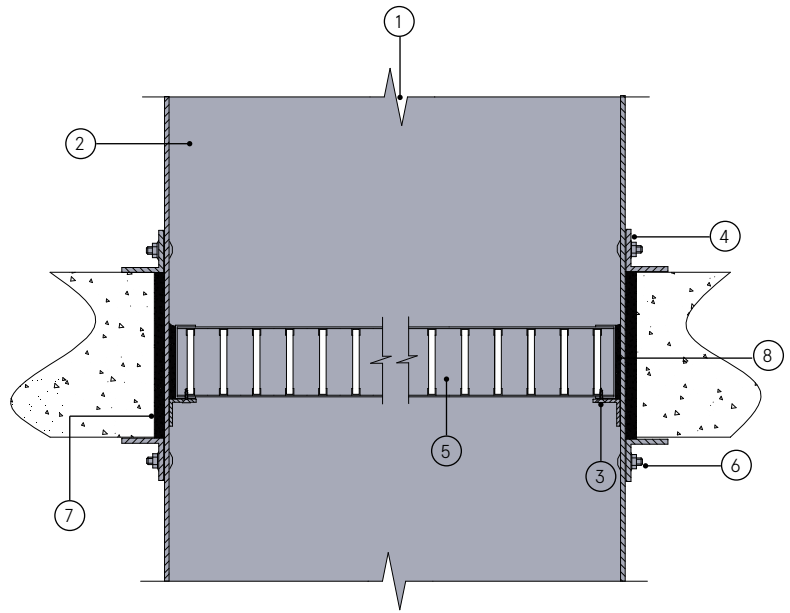

### CONTENTS

- LVH44 air transfer grille

### TOOLS REQUIRED

- Self tapping screws (3.2mm x 16mm)
- Masonry anchors
- Mounting flange
- Supporting bracket (20 x 20 x 1mm)
- Lorient intumescent sealant

▶▶ **Note:** If no reticulating ductwork is above the slab a protective and load-bearing grate is necessary.

### Masonry floor (duct to duct)

## FR120

### Fire Resistance in accordance with

BS 476-22:1987

### Approval Ref

WFRC C121316 (F1)

### Max single cell size

1200 x 600mm

LVH44 air transfer grilles are supplied 2mm less than the nominal size e.g. a 300mm x 300mm is actually 298mm x 298mm.

### INSTALLATION INSTRUCTIONS

- ▶ Fix a supporting bracket into the duct section either welded in place, or using M3 bolts.
- ▶ Fix the LVH44 into duct and seal around the perimeter with intumescent sealant.
- ▶ Fix to supporting angles with 3.2mm x 16mm self tapping screws.
- ▶ Check the mounting flange size is not less than twice the clearance between the LVH44 and opening.
- ▶ Fit one set of mounting flanges to the LVH44 assembly and lower the air transfer grille assembly into the floor opening. Ensure the assembly sits squarely and penetrates the floor opening.
- ▶ Fill the outside perimeter of the LVH44 with Lorient intumescent sealant.
- ▶ Fit mounting flanges on underside of floor using M5 bolts. Ensure flanges are hard against the floor and the fixings are adequately tightened. Check the LVH44 assembly sits squarely in the opening.
- ▶ Connect ductwork directly to floor using approved breakaway connections to ensure compliance.
- ▶ Apply a bead of Lorient intumescent sealant between casing and the floor (note: maximum clearance of 10mm applies).
- ▶ Ensure convenient access is provided for easy inspection and cleaning as necessary.



# FLOOR 10

## MASONRY FLOOR (DUCT TO GRILLE)

### DESCRIPTION

- 1 Load bearing cover grate required
- 2 Light gauge galvanised casing
- 3 Damper retaining bracket 1mm galvanised steel fixed with short self tapping screws
- 4 Mounting angles
- 5 LVH44 air transfer grille
- 6 M5 bolts for mounting angles.
- 7 Lorient intumescent sealant between casing and concrete slab
- 8 Lorient intumescent sealant between LVH44 and casing
- 9 Independent duct fixing complete with breakaway joints.

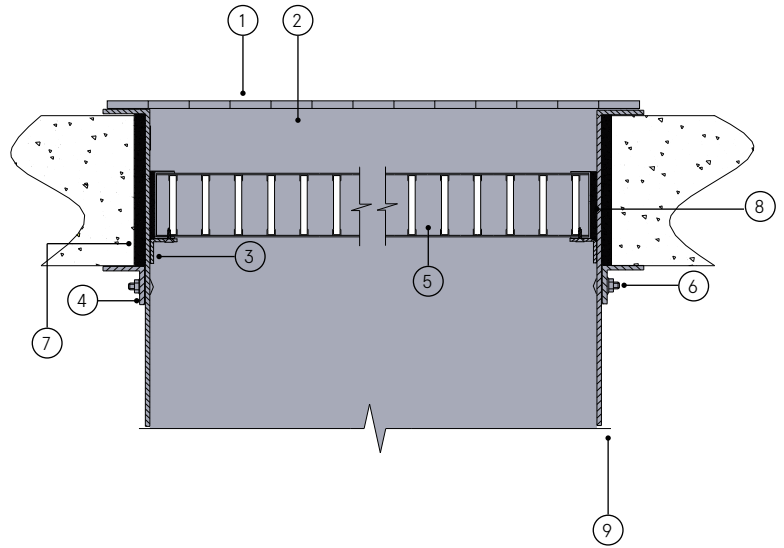

### CONTENTS

- LVH44 air transfer grille

### TOOLS REQUIRED

- Self tapping screws (3.2mm x 16mm)
- Masonry anchors
- Mounting flange
- Supporting bracket (20 x 20 x 1mm)
- Lorient intumescent sealant

**▶▶ Note:** If no reticulating ductwork is above the slab a protective and load-bearing grate is necessary.

### Masonry floor (duct to grille)

## FR120

### Fire Resistance in accordance with

BS 476-22:1987

### Approval Ref

WFRC C121316 (F2)

### Max single cell size

600mm x 600mm

LVH44 air transfer grilles are supplied 2mm less than the nominal size e.g. a 300mm x 300mm is actually 298mm x 298mm.

### INSTALLATION INSTRUCTIONS

- ▶ Fix supporting bracket into the duct section either welded in place, or using M3 bolts.
- ▶ Fix the LVH44 into duct and seal around the perimeter with intumescent sealant.
- ▶ Fix to supporting angles with 3.2mm x 16mm self tapping screws.
- ▶ Check the mounting flange size is not less than twice the clearance between the LVH44 and opening.
- ▶ Lower the LVH44 into the floor opening.
- ▶ Fill the outside perimeter of the LVH44 with Lorient intumescent sealant.
- ▶ Fit mounting flanges on underside of floor using M5 bolts. Ensure flanges are hard against the floor and the fixings are adequately tightened. Check the LVH44 assembly sits squarely in the opening.
- ▶ Apply a bead of Lorient intumescent sealant between casing and the floor (note: maximum clearance of 10mm applies).
- ▶ Ensure convenient access is provided for easy inspection and cleaning as necessary.

# TALKBACK DAMPER CONTROL SYSTEM

All ducts and airways in doors and walls can be protected against fire and hot smoke using Lorient intumescent air transfer grilles. However, these grilles will not prevent the passage of cold smoke which can be equally dangerous.

To address this problem Lorient has developed a smoke damper/shutter assembly for use in conjunction with Lorient intumescent air transfer grilles.

The unique 2-way communication system between the Damper Control & Monitor Unit (DCM) and the damper actuators facilitates rapid assessment of serviceability of the installation and immediately identifies the location of a defective damper.

The "Talkback" system comprises a "Damper Control & Monitor" (DCM) and up to 16 uniquely addressed damper/shutter

assemblies. The interconnecting 3-core cable can be installed as a "ring" for greater reliability and maximum range, or it may be spurred if necessary.

An extra optional audio warning device (AMS) can be connected to the DCM wiring circuit as shown in diagram "A" (pg.5). This device would be incorporated to draw attention to the DCM status display in the event of a fault occurring. It may also be connected to the B.M.S to provide a fault indication.

## PLEASE NOTE

The DCM also incorporates connection for a battery backup option, as shown in wiring instructions. An appropriate rechargeable battery and enclosure is available from Lorient if required.



## TYPICAL INSTALLATION OF THE LORIENT TALKBACK SYSTEM

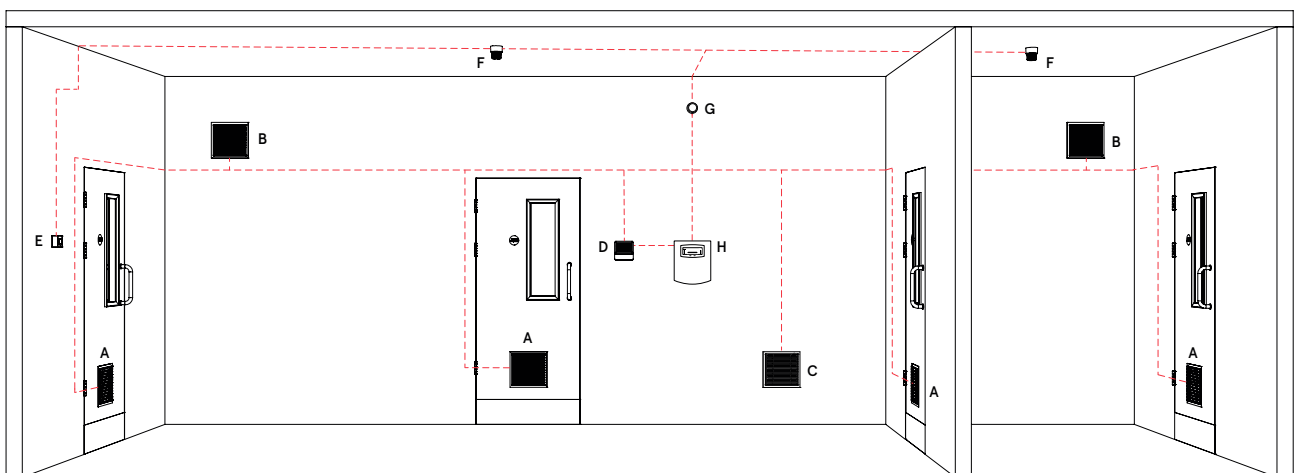

A: Door mounted fire + smoke air transfer grilles  
 B: End of duct fire + smoke air transfer grilles  
 C: Wall mounted fire + smoke air transfer grilles

D: Power + monitor unit  
 E: Fire point  
 F: Smoke sensors

G: Fire alarm  
 H: Fire alarm panel

# WIRING LAYOUT

## TALKBACK DAMPER CONTROL SYSTEM - SCHEMATIC WIRING INSTALLATIONS

- Live
- Negative
- Signal

**DIAGRAM A:**  
Ringed wiring  
installation

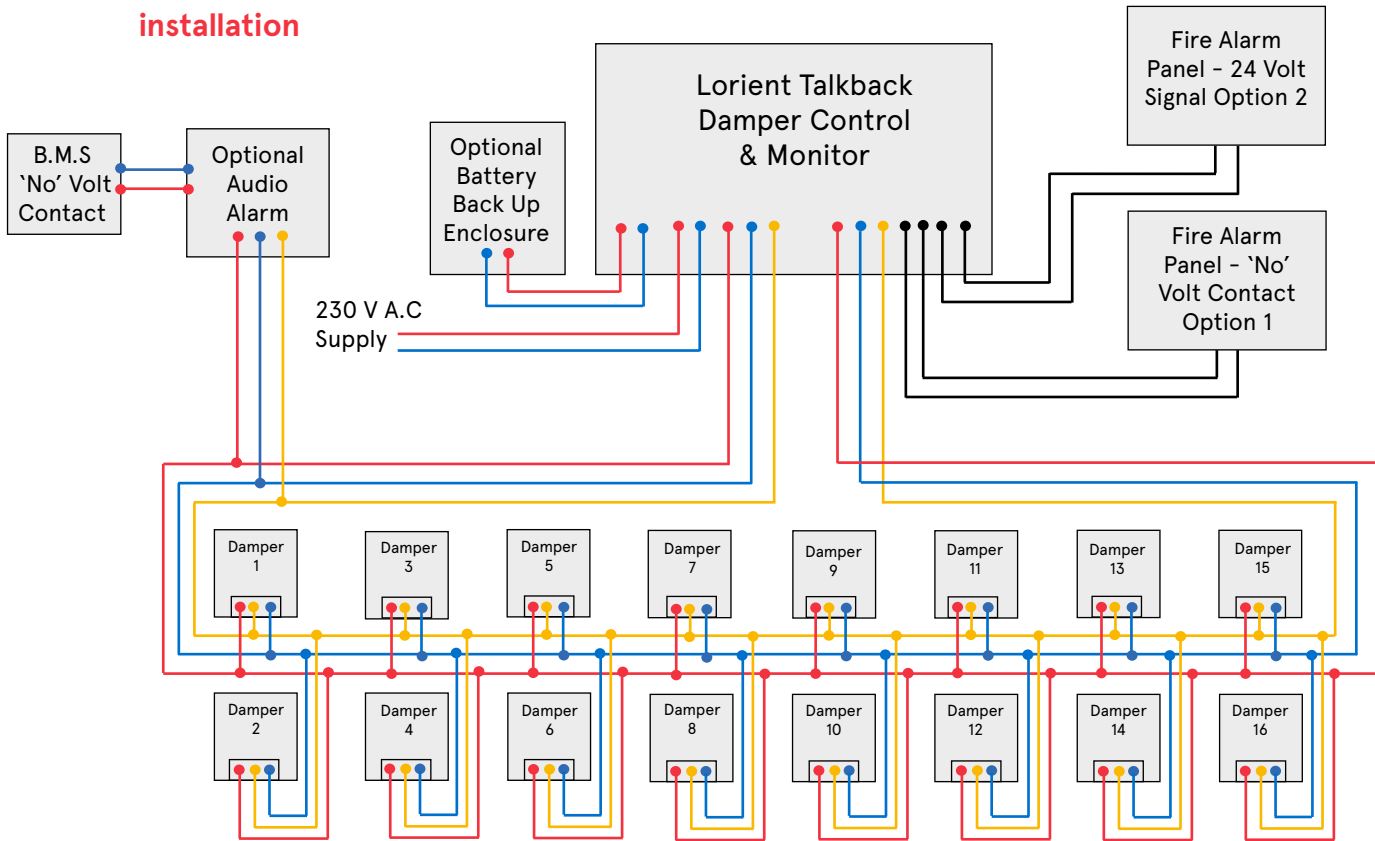

**DIAGRAM B:**  
Spurred wiring  
installation

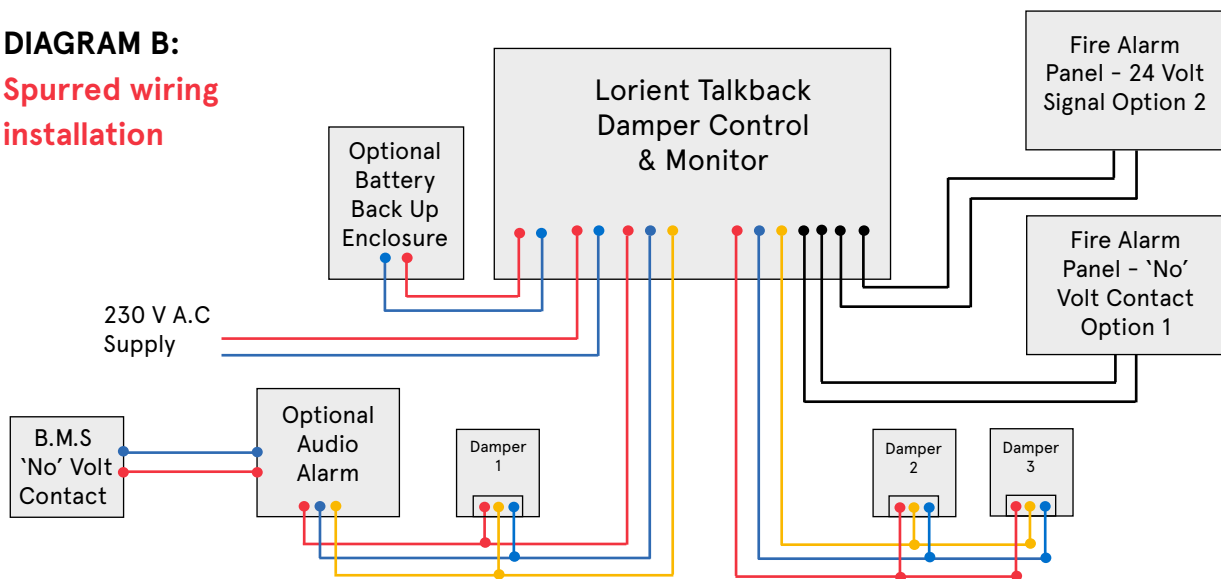

# DIAGRAM C: Connections within Talkback Damper Control + Monitor

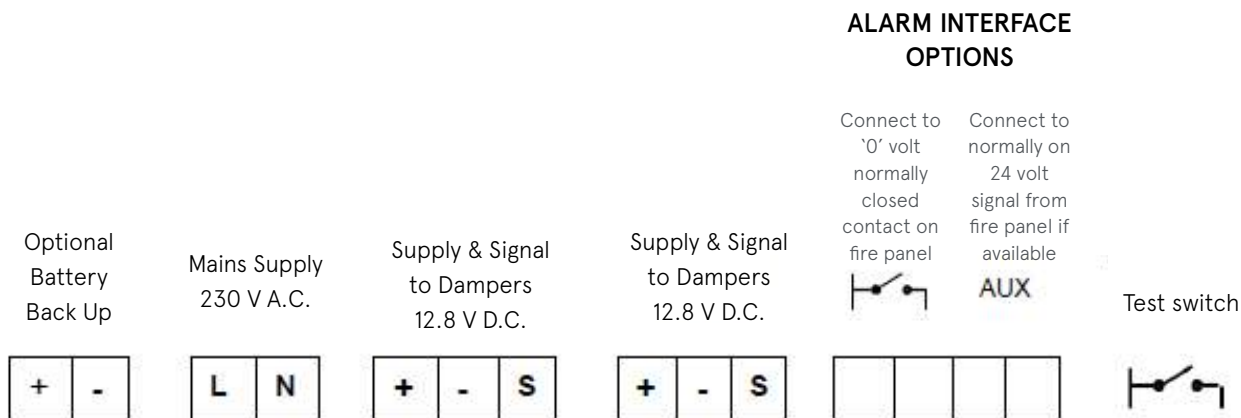

Each DCM can control up to 16 air transfer grilles or dampers. Each air transfer grille or damper must be assigned its own address from 1 to 16. A shared address will cause the system to fail. The address of any damper can be changed by adjusting the rotary switch on the front of the actuator as shown in below.

As we are unaware of the placement of the individual dampers we cannot set the address to correspond with the damper control system. Each unit should only have 1 x no. 1, 1 x no. 2, 1 x no. 3, etc connected to it.

**PLEASE ENSURE YOU SET THE ADDRESS ON THE ACTUATOR BEFORE CONNECTING THE SYSTEM TO THE MAINS SUPPLY.**

This is done by using a small flat bladed screwdriver and turning the rotary switch.

Options shown: 1 2 3 4 5 6 7 8 9 A B C D E F O  
 Equates to: 1 2 3 4 5 6 7 8 9 10 11 12 13 14 15 16

The pictures below show the location of the rotary switch:

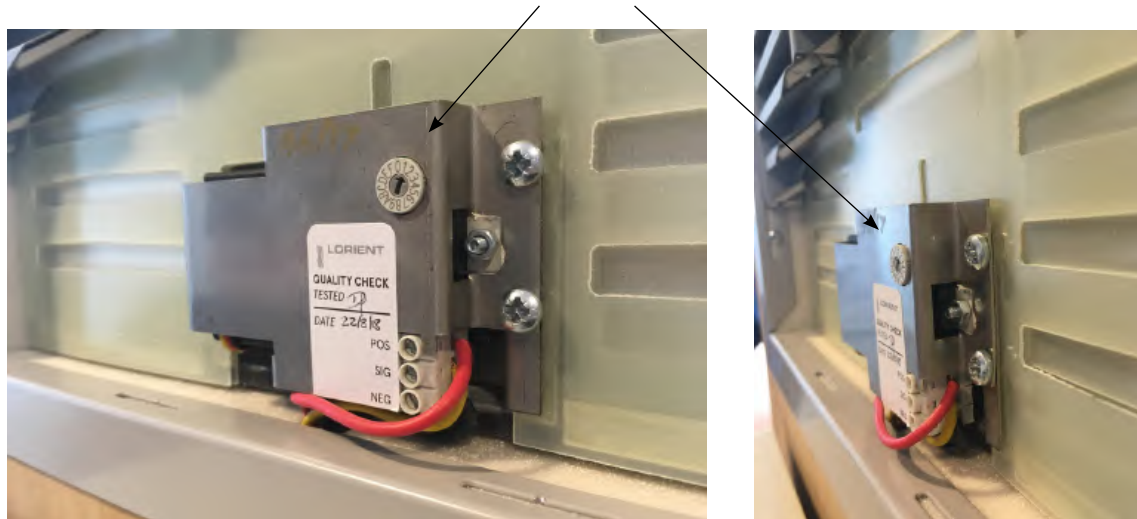



# ATG COMMISSIONING + MAINTENANCE

We offer a professional and expert commissioning service for fire + smoke resistant air transfer grilles.

We check and test the installation and components of Lorient fire + smoke resistant air transfer grilles; and issue a fully detailed service report, highlighting status and compliance.

Our comprehensive service covers a number of factors, including:

- ▶ Checking the system is installed as per Lorient recommendations and is compliant with test evidence.
- ▶ Checking the full functionality of the system, which can be coupled with witness testing to demonstrate functionality and compliance if required.

- ▶ Providing documented evidence that the system is functioning as per requirements.
- ▶ Providing documented installation detail, which can be used in off-site support and/or included in site handover.
- ▶ Reducing delays caused by improper installation which require technical support.

Please contact our Testing + Technical Services team for pricing and further information on **+44 (0)1626 834252** or email [inspections@lorientuk.com](mailto:inspections@lorientuk.com)

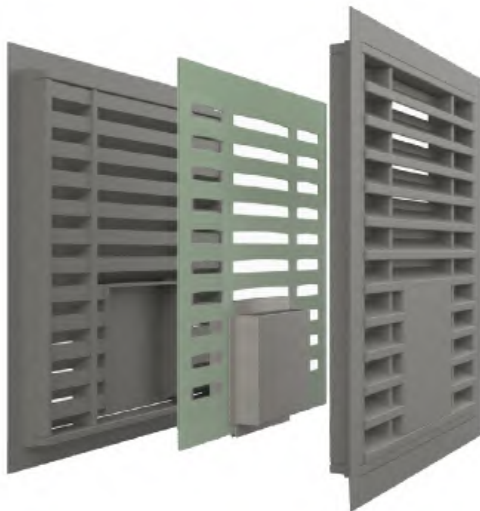

▲  
**LVN20S**  
in open position



▲  
**LVN20S**  
in closed position

Call our Technical Services team  
**+44 (0)1626 834252**



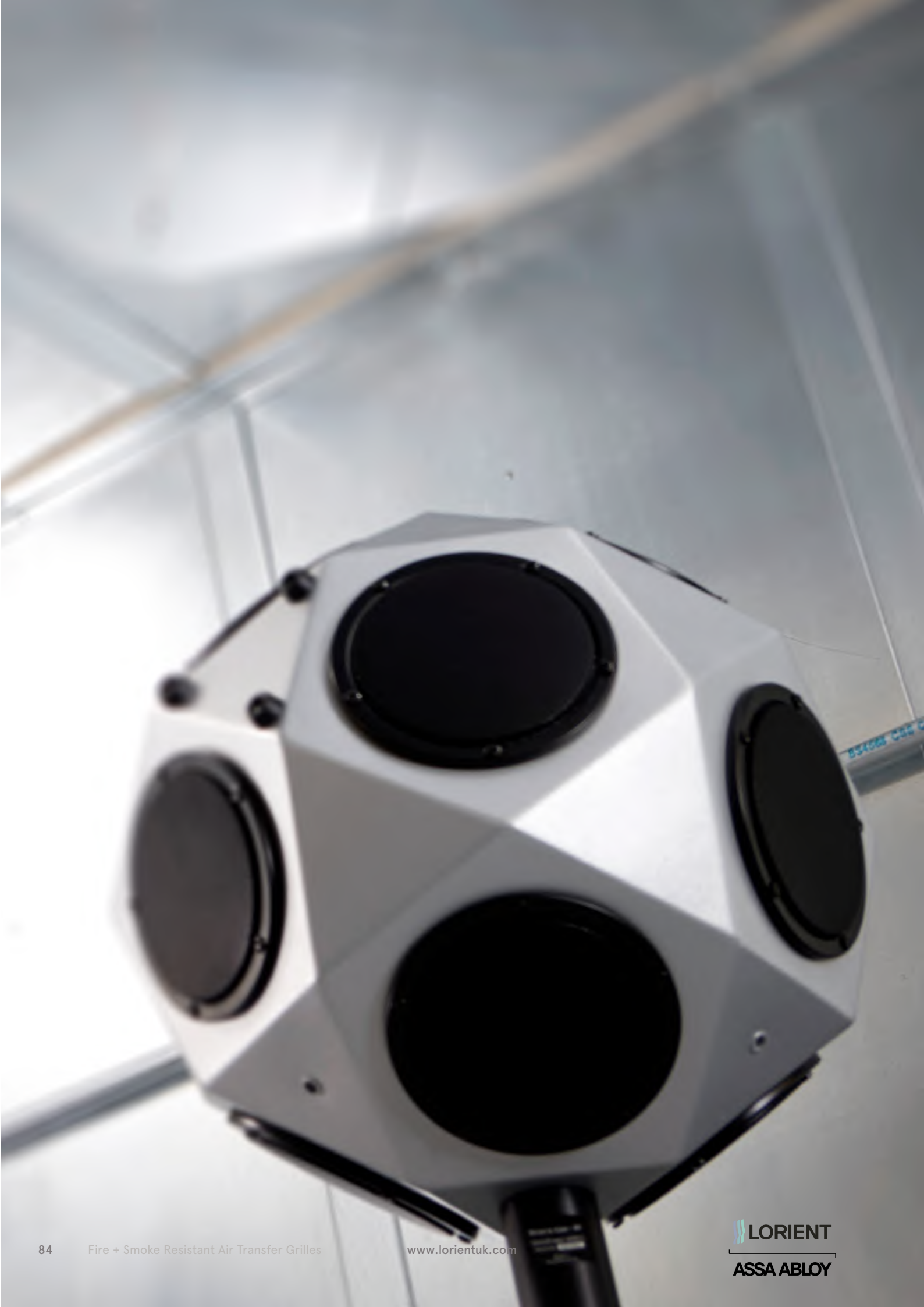

# TESTING + TECHNICAL SERVICES

We've built our reputation on the quality and dependability of our products, and our investment in R&D has played a pivotal role in keeping our products at the forefront of our industry. Our dedicated Testing and Technical Services division has established itself as an important facility for manufacturers and designers of doors, windows, glazing systems and hardware, to name just a few.

## TESTING SERVICES

Whether you're investigating new materials, or developing new or existing products, right through to durability testing and benchmarking performance – our team of experts will support you throughout the process. We are able to offer:

- ▶ Fire testing (indicative)
- ▶ Smoke leakage
- ▶ Air leakage
- ▶ ATG commissioning and maintenance for fire & smoke resisting air transfer grilles
- ▶ Mechanical cycling
- ▶ Environmental chamber analysis
- ▶ Attendance at external fire tests
- ▶ Consultancy services.

▲  
Lorient Indicative Furnace



# ADDITIONAL INFORMATION

## TECHNICAL REFERENCES

Lorient is quality assured under the disciplines of BS EN ISO 9001:2015.

Accreditation to this standard is an assurance that we conduct our business to the complete satisfaction of our customers with regard to design solutions, manufacturing consistency and management procedures.

As a result, this internationally recognised standard for quality management generates customer confidence. Regular audits of our company procedures are undertaken by qualified BSI staff to ensure ongoing compliance with all aspects of the standard.



BS EN ISO 9001:2015 Certificate No. Q6104

Lorient has attained the BS EN ISO 14001:2015 accreditation for environmental management, making us the first seal manufacturer to have achieved this important award. This internationally recognised standard shows that we have demonstrated our commitment to responsible environmental behaviour, including prevention of pollution, control and reduction of waste, and ongoing monitoring and improvement of our environmental performance. Achieving ISO 14001 is just one part of our ongoing commitment to operate in a sustainable way.



BS EN ISO 14001:2015 Certificate No. EMS 541906

## FITTING INSTRUCTIONS

Comprehensive fitting instructions are available to download from our website [www.lorientuk.com](http://www.lorientuk.com)

## MAINTENANCE

### INTUMESCENT FIRE ONLY AIR TRANSFER GRILLES

Lorient intumescent air transfer grilles, including those positioned behind cover grilles, will require periodic cleaning with a damp cloth. Visually inspect the air transfer grilles structure and free pathway for signs of corrosion, dirt or dust.

The use of intumescent materials means there are no moving parts. The product is trouble free in operation and easy to maintain – periodic testing is unnecessary.

### TALKBACK FIRE AND SMOKE AIR TRANSFER GRILLES

Inspect actuator, shutter plates, DCM including indicator lamps for dust, dirt or damage.

Check and ensure correct operation of plate mechanism, i.e. opening and closing, check for plate separation or sticking. Verify connection to DCM and the damper is functioning by utilizing the test function by appropriately qualified personnel. Report any defects and record all actions undertaken.

## HANDING + STORAGE

No special precautions are required when handling Lorient air transfer grilles / dampers, but they should always be treated with care. The products do not fall within the scope of COSHH regulations. Lorient dampers/air transfer grilles should be stored away from heat, in the dry, and protected from impact damage.

## GUARANTEE OF ORIGIN

Each production is identified unobtrusively on the edge of the air transfer grille with the Lorient name and a code reference. This ensures the product and details of its production can be traced should the need arise.

Unidentifiable substitute products should never be accepted.

## MADE IN BRITAIN

We are proud to have been granted the prestigious Made in Britain marque for our products, designed and manufactured at our main facility in South West of the UK.



## INTELLECTUAL PROPERTY

© 2024 Lorient – this brochure is protected by copyright and neither the drawings nor the text may be reproduced or transmitted in any form without prior consent from Lorient. Lorient products described in this brochure are protected by patents and design registrations in Great Britain and other countries.

We are committed to continually enhancing and improving our product range. We reserve the right to change product specifications from time to time without prior notice. E&OE.

June 2024.

## TRADE ASSOCIATIONS

Lorient is a member and active contributor to the following:



## ACCREDITATIONS

### BBA

BBA approvals provide independent assurance for the designer, specifier and end-user as to the 'fitness for purpose' of building products.

### CERTIFIRE

Operated by Exova Warringtonfire, CERTIFIRE is an accredited independent product conformity scheme that requires products to meet the requirements of the tests, to add minimal resistance to opening and closing forces, to prove long term performance under a variety of service conditions, and to be permanently marked for easy identification.

### IFC

IFC Certification Ltd is a UKAS approved and internationally recognised provider of third party Certification services – designed to give confidence to specifiers, users, occupiers, owners and enforcement bodies that products have been thoroughly and independently evaluated and will continue to be manufactured to the same specification as originally tested.

### UL

UL is a global independent safety science company that tests a diverse range of products; representative samples of a product must be tested and meet UL's stringent requirements to carry the marque. These requirements are based primarily on UL's published and nationally recognised Standards for Safety. Businesses, consumers and regulatory authorities around the world recognise the trusted rigour and technical excellence of UL certifications. Lorient is proud to have achieved the UL Mark on many of its products. These are detailed on individual pages.

# CPDs

We offer three fully-accredited CPD seminars. Impartially presented by knowledgeable speakers, the seminars are structured to be technically informative, and provide practical advice.

## Performance Door Design: The Basics of Sound Reduction

Effective acoustic containment helps to improve the quality of the built environment, preserving privacy as well as excluding unwanted noise. With changing regulations, it's essential to be informed of the relevant requirements and the implications for door assemblies.

Our acoustic CPD seminar covers:

- ▶ the nature of sound, examining airborne transmission of sound;
- ▶ regulatory requirements and British Standards that relate to acoustic performance;
- ▶ test procedures and interpretation of test reports;
- ▶ effective design of door assemblies for acoustic performance, including door construction and the influence of sealing systems;
- ▶ design conflicts between acoustic performance, durability and ease of operation of the door;
- ▶ independent accreditation.

## The Role and Performance of Fire and Smoke-Resisting Door Assemblies

The importance of fire and smoke resisting door assemblies is illustrated by the 216 fire related fatalities and 5,545 casualties in fires (England 2022/23). Apart from the human toll, property losses each year approach £2.52 billion.

Our fire and smoke containment CPD seminar covers:

- ▶ hard facts concerning deaths, injuries and property damage caused by fire and smoke;
- ▶ regulatory requirements for fire and smoke resisting door assemblies;
- ▶ the nature and behaviour of smoke;
- ▶ effective design of door assemblies for smoke containment, including the threshold gap;
- ▶ design conflicts between fire containment, smoke containment, durability and ease of operation of the door;
- ▶ independent accreditation.

## The Regulatory Reform (Fire Safety) Order 2005 and its implications for fire doors

The RRO consolidated 70 pieces of legislation; shifted responsibility for fire safety management; abolished the Fire Safety Certificate; established the Fire Risk Assessment and created major change in legal liability.

Our RRO CPD seminar covers:

- ▶ an overview of the RRO;
- ▶ product solutions;
- ▶ the dangers of fire and smoke;
- ▶ the importance of fire doors – including installation and maintenance.

Our CPD materials have been independently verified and certified by the RIBA as CPD approved. A certificate for 1 hour's CPD will be provided, which contributes to Continuing Professional Development requirements.

If you are interested in booking a seminar, please contact our Marketing department or email [cpd@lorientuk.com](mailto:cpd@lorientuk.com)

# AIR TRANSFER GRILLE CPD WEBINAR

We're delighted to offer a CPD entitled:  
The Specification + Design of Air Transfer Grilles / Dampers.

This is a fantastic addition to our growing collection of CPD seminars and explores:

- ▶ the latest test standards and building regulations;
- ▶ the major difference between intumescent air transfer grilles and dampers;
- ▶ the importance of correct specification, installation and maintenance;
- ▶ plus it offers practical solutions to fire and smoke containment over a range of applications.

All of our CPD seminars are available to view virtually, please speak to our Marketing Department for further information on 01626 834252 or email [mktg@lorientuk.com](mailto:mktg@lorientuk.com)

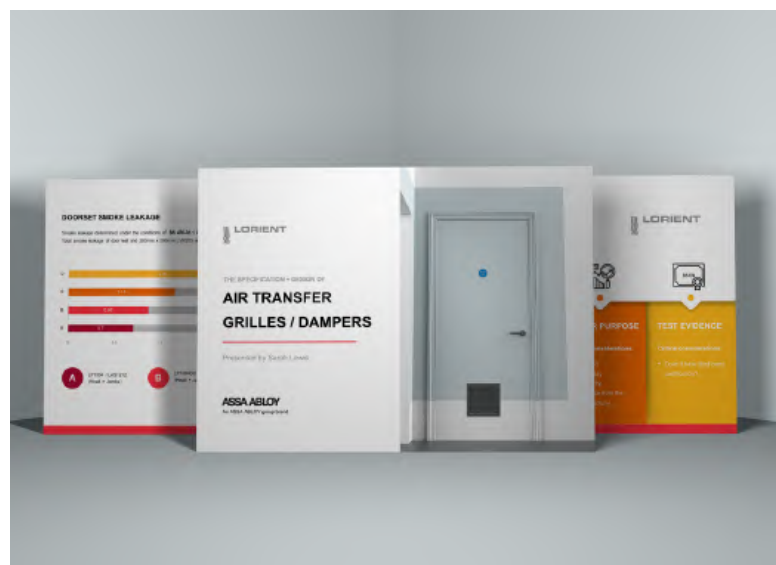

# COMPREHENSIVE SUPPORT

We continue to lead the way in Research + Development. As a company we have over 40 years' experience, so our experts are well equipped to listen, help and advise you on your sealing system requirements.

## Technical Services

We're happy to provide specialist advice on acoustic, smoke and fire protection for refurbishment and new build projects. If you need assistance, you can call our Technical Services team.

Alternatively, we can arrange a site visit to get a clearer idea of your needs and how we can help you. We also provide copies of test reports and samples where needed; and can give guidance on how best to meet Building Regulations and Standards.

## Web Support

Our website features a comprehensive range of supporting documents covering the entire range of products, including installation guides and CAD drawings. All of our brochures and product datasheets are also available for download, together with copies of certification and specification texts.

## Customisation

If you have a particular requirement which isn't covered by the applications in this brochure, we may be able to supply an existing non-standard item, or even develop a customised solution for you. Utilising in-house expertise, bespoke products are created to your requirements; from a functional or aesthetic perspective, or both.

Lorient's dedicated Technical Services team supports and works as part of your design team, offering informed product advice and guidance on regulatory requirements and standards.



Call our Technical  
Services team  
**+44 (0) 1626 834252**

[www.lorientuk.com](http://www.lorientuk.com)

---

# SEALING SOLUTIONS

Detailed information about our products can be found in the following brochures:

## Acoustic Sealing Systems for Door Assemblies

A comprehensive series of acoustic sealing systems for various types of door construction.

## Acoustic, Smoke and Fire Seals for Door Assemblies

Our core range of high performance acoustic, smoke and fire seals.

## AURA® Architectural Seals

A discerning selection of drop seals, perimeter seals, door bottom seals, threshold plates and ramps - all with strong design accents.

## Lorient Architectural Seals

A variety of complementary door sealing systems including perimeter seals, drop seals, threshold plates, door bottom seals etc.

## Fire Resistant Door Hardware Protection

Letterplates, door viewers, door edge protectors and intumescent kits that can safely be installed into fire rated doors without compromising the fire/smoke performance.

## Fire Resistant Glazing Systems

Fire resistant glazing systems for doors, screens and partitions.

## Fire and Smoke Resistant Air Transfer Grilles

A comprehensive range of intumescent air transfer grilles for doors, walls, ducts, floors and ceilings.

Copies of these brochures are available by calling **01626 834252** or download from our website **[www.lorientuk.com](http://www.lorientuk.com)**



**UK / EUROPE**

T: +44 (0) 1626 834252  
E: sales@lorientuk.com

**HONG KONG**

T: +852 2260 0888  
E: sales@lorienthk.com

**AUSTRALIA**

T: +61 (0) 3 8574 3888  
E: customerservice.au@assaabloy.com

**UAE**

T: +971 4 8804888  
E: mktg@lorientuk.com

**SINGAPORE**

T: +65 6880 0000  
E: sales.lorient@assaabloy.com

**USA**

T: +1 859 252 7441  
E: info@lorientna.com

S F E R  
E

For further information about  
Lorient products please visit:  
[www.lorientgroup.com](http://www.lorientgroup.com)