

IS1212 Curved Fin Batwing® acoustic and smoke seal

The Lorient IS1212 Curved Fin Batwing® seal couples highly effective acoustic and smoke sealing with simple installation.

As well as excellent acoustic performance, the Lorient IS1212 Curved Fin Batwing® has plenty to offer:

- successfully tested in accordance with BS476: Pt 31.1 for smoke sealing
- new curved fin minimizes open/closing resistance
- elastomeric fins ensure ongoing product flexibility and performance over time
- exceptional durability – tested to over 1,000,000 operating cycles
- suitable for new build projects, or refurbishing existing doors
- carries both BBA and CERTIFIRE (CF136) approvals

In addition to the IS1212, there are also other sizes available in the Batwing® range. The IS1515 and IS1010 are slightly larger and smaller versions of the IS1212. But for kerf fitting installations, the IS1212K is an ideal choice.

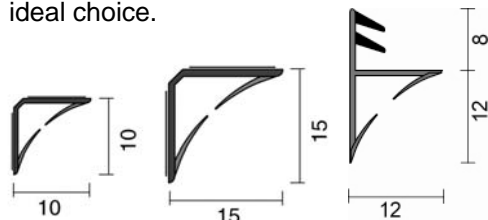

IS1010

IS1515

IS1212K

Plus, all the Lorient Batwing® products are available in a **range of colours as standard** – black, brown, white, cream or silver grey.

IS1212 Curved Fin Batwing® fitting instructions

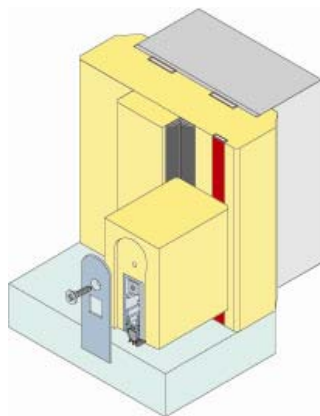

The IS1212 Curved Fin Batwing® fitted into the frame of a door assembly, shown with the IS8010 si fitted in the threshold of the door.

The IS1212 Curved Fin Batwing® is fitted on to the door stop – see diagram above. It is important that there is a 2-4mm gap between the door and the door stop to enable the door to close. Tight gaps will dislodge the seal from its position.

Remove the IS1212 Curved Fin Batwing® from packaging. Measure door perimeter and trim IS1212 Curved Fin Batwing® to length as required using snips.

Peel the backing tape from the adhesive on both sides of the IS1212 Curved Fin Batwing® approximately 100mm.

Mount in the top corner, using a jointing method as tight as possible to ensure continuity of seal.

Run finger down the centre of the profile, pushing it into the reveal.

Pull adhesive backing strips off both legs a little at a time, progressively pushing the seal into place.

The importance of threshold sealing

Despite the recommendations of Document E to seal the threshold “where practical”, research shows that it is **essential** to do so in order to achieve the required 29dB Rw. Threshold sealing is also vital for providing protection against smoke.

This pack contains the IS8010 si automatic threshold seal, part of Lorient’s Integrity™ Architectural Seals range. The IS8010 si has a high efficiency mechanism which lifts the seal clear of the floor as soon as the door is opened by a few millimetres – no power connection is required.

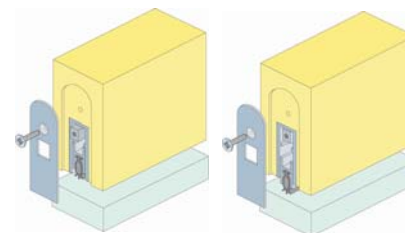

The IS8010 si in raised (left - door open) and lowered (right - door closed) positions

The IS8010 si also has:

- a durable silicone gasket
- a light action, for ease of door opening, closing and latching
- internal fins which provide exceptional acoustic performance
- CERTIFIRE approval (CF136)
- exceptional durability - tested to over 1,000,000 operating cycles
- Now also tested under the conditions of BS EN 1634-1:2000

Please refer to the separate detailed fitting instructions for the IS8010 si which are included in this pack.



Everything you need
to meet the
requirements of



Pack E2

Doorset pack for
acoustic containment

Suitable for standard door size:

2040 x 926mm

(will fit door size up to 2100 x 935 mm)

Contains:

- IS1212 Curved Fin Batwing®: 5 x 1050mm lengths;
- IS8010 si: 1 x 935mm length (can be cut back to a minimum length of 835mm)



DOC



This pack contains everything you need

to enable you to meet the requirements for door assemblies detailed in Approved Document E to the Building Regulations (England & Wales).

The revisions to Document E came into effect on 1 July 2003. From that date, all planning applications requiring Building Control approval, and work carried out under Building Notice procedures, have to comply with the revised Regulations.

Much of Document E relates to the acoustic performance of floors, ceilings and walls. However, for the first time, the acoustic performance of **door assemblies** in a number of situations is also specifically detailed. Everyone involved in the specification and installation of door assemblies will need to be certain they know what the requirements are, and what they need to do to ensure they comply with the new regulations.

This pack contains:

- **helpful information** about Document E and how it relates to door assemblies
- **perimeter and threshold seals** sufficient for one single leaf single swing doorset
- **clear instructions** to ensure the products can be fitted correctly
- **information about the relevant test evidence and accreditations** applicable to the products
- **details of technical support** available, and how to find out more information

The facts about Approved Document E: what the regulations say

The requirement reads:

"Dwelling-houses, flats and rooms for residential purposes, shall be designed and constructed in such a way that they provide reasonable resistance to sound from other parts of the same building and from adjoining buildings."

Door assemblies form an integral part of buildings, and while there must be gaps around the perimeter of a door for it to operate, these gaps also enable **fire, smoke and sound** to pass through. It is therefore **essential** to consider the acoustic sealing of door assemblies in order to comply with the requirements of Document E.

Document E goes on to give specific guidance for the acoustic performance of door assemblies. Clauses 2.26, 4.20 and 6.6 reads:

*"Ensure that any door has **good perimeter sealing (including the threshold where practical)**, and a minimum mass per unit area of 25kg/m² or a **minimum sound reduction index of 29dB Rw** (measured according to BS EN ISO 140-3: 1995 and rated according to BS EN ISO 717-1:1997). The door should also satisfy the Requirements of Building Regulation Part B – Fire safety."*

A typical architectural door leaf has a mass of only 18-22kg/m² – below the requirement stated in Approved Document E – and therefore it is essential to establish the acoustic performance of the doorset to at least 29dB Rw.

Document M

With the 2004 revision to Document M, access for all - not only disabled people - is high on the agenda, so doors must provide a minimal barrier to access, and are required to be much easier to operate. The Curved Fin Batwing[®] now features fins that are subtly curved to work with the door leaf; the seal provides minimal frictional resistance, so the door remains easy to operate, contributing to Document M requirements.

The importance of perimeter sealing

Without any seals fitted, a standard architectural solid core door leaf will only provide acoustic performance in the region of 22dB Rw. Even with a traditional brush smoke seal fitted, the performance will only be in the region of 23-24dB Rw. A seal with an elastomeric blade which bypasses the hinge – such as the Lorient IS1212 Curved Fin Batwing[®] seal included in this pack – coupled with an effective threshold seal, has been proven to provide superior acoustic performance to meet and exceed the 29dB Rw requirement of Document E.

The importance of sealing at the hinge and latch points

Cutting away an acoustic seal at the hinge and latch points seriously detracts from the acoustic performance of the doorset. The Lorient IS1212 Curved Fin Batwing[®] seal in this pack has been designed to fit in the corner of the door stop. This means it completely bypasses ironmongery to ensure the acoustic seal is maintained. It also provides smoke protection.

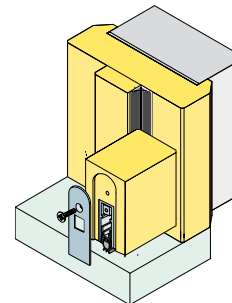

Please turn over for more information about the IS1212 Batwing[®] seal and detailed fitting instructions.

Test evidence

The product combination included in this pack (IS1212 Curved Fin Batwing[®] and IS8010 si) has been acoustically tested in accordance with the standards stated in Document E. On a typical architectural solid core door, this product combination has been proven to give an acoustic performance of **31dB Rw**. (This is in excess of the 29dB Rw requirement of Document E to allow for a potential shortfall due to the difference between the ideal laboratory test conditions and on-site conditions.) *For further information about Lorient's acoustic test evidence, or a copy of any test reports for Lorient products, please call Lorient's Technical Helpline on +44 (0)1626 834252.*

Third Party Accreditations

Lorient holds third party accreditations on many of its products. These provide independent verification and assurance of product quality. The IS1212 Batwing[®] holds both British Board of Agrément and CERTIFIRE (CF136) certificates. The IS8010 si holds CERTIFIRE (CF136). Copies of certificates are available on request from the Lorient Technical Department on +44 (0)1626 834252.

Lorient is quality assured under the disciplines of BS EN ISO 9001:2000



BS EN ISO 9001:2000
Cert. No. Q6104

Lorient Polyproducts Ltd

Tel: +44 (0) 1626 834252
Fax: +44 (0)1626 833166
Sales: +44 (0)1626 837500
www.lorientuk.com